

Installation and Operating Handbook

UPC7000 Series Automatic Up-Link Power Controller

Covers software version 2.00 and above

Handbook Issue 2.17, 3rd June 2024



PEAK COMMUNICATIONS Ltd.
Unit 1, The Woodvale Centre, Woodvale Road,
Brighouse, West Yorkshire
HD6 4AB, England

Phone +44 (0)1484 714200
Fax +44 (0)1484 723666



**IMPORTANT NOTE: THE INFORMATION AND SPECIFICATIONS
CONTAINED IN THESE DOCUMENTS SUPERSEDE ALL PREVIOUSLY
PUBLISHED INFORMATION CONCERNING THESE PRODUCTS**

Table of Contents

CUSTOMER CARE	5
PRODUCT COMPLIANCE	6
Safety	6
EMC	6
1. INTRODUCTION	7
1.1 General product overview & principles of operation	7
1.2 Functional description	8
1.2.1 Internal Beacon Receiver – Functional description & operating suggestions.	10
1.3 UPC7000 Specifications	11
1.3.1 Input Section	11
1.3.2 UPC Section.....	12
1.3.3 Output Section	13
1.3.4 General	14
1.4 Review of UPC7000 Specification parameters	15
1.4.1 External Beacon Receiver	15
1.4.1.1 External Beacon Receiver Input.....	15
1.4.2 Internal Beacon Receiver DownConverter section	15
1.4.2.1 DownConverter Input	15
1.4.2.2 DownConverter resolution.....	15
1.4.2.3 DownConverter Conversion Gain.....	15
1.4.2.4 Auxiliary DC and 22KHz tone.....	15
1.4.2.5 10MHz reference output.....	15
1.4.3 Internal Beacon Receiver Tracking Section	16
1.4.3.1 Tracking Output.....	16
1.4.3.2 Tracking Level	16
1.4.3.3 Sweep Range.....	16
1.4.3.4 Sweep Rate.....	16
1.4.3.5 Post Detection Time Constant.....	16
1.4.3.6 Log Output Scale.....	16
1.4.3.7 DC Output Adjustment	16
1.4.3.8 PLL Noise Bandwidth	16
1.4.3.9 Threshold for Reacquisition.....	16
1.4.3.10 ASB Sweep Rate.....	16
1.4.3.11 ASB Threshold	16
1.4.4 Internal Beacon Receiver Video Section	17
1.4.4.1 Video Input	17
1.4.4.2 Video Resolution	17
1.4.4.3 Vertical Resolution	17
1.4.4.4 Video Section Attenuator.....	17
1.4.4.5 Reference frequency	17
1.4.5 UPC Section	17
1.4.5.1 Compensation Range.....	17
1.4.5.2 Step Size.	17
1.4.5.3 Compensation ratio.	17
1.4.5.4 Slew Rate.	18
1.4.5.5 Sample Period.....	18
1.4.6 Output Section	18
1.4.6.1 Internal UpLink Channel Compensation Circuit Input.	18
1.4.6.2 Internal UpLink Channel Compensation Circuit Output.	18
1.4.6.3 Internal UpLink Channel Compensation Circuit Bypass Connections.	18
1.4.6.4 1dB Gain Compression Point.....	19
1.4.6.5 Insertion Loss and Attenuation.....	20
1.4.6.6 Gain Flatness.	20
1.5 Mechanical description	20
1.6 Front panel description	21
1.7 Rear panel description.....	21
1.7.1 Chassis Earth stud	21

1.7.2 Rx In	22
1.7.3 Rx Out	22
1.7.4 Ext Ref.	22
1.7.5 UpLink Channel Compensation 'In'.....	22
1.7.6 UpLink Channel Compensation 'Out'.....	22
1.7.7 UpLink Channel Compensation 'Bypass'.....	22
1.7.8 Alarms connector	22
1.7.9 RS232/RS485 Remote Control connector.....	22
1.7.10 Redundancy	23
1.7.11 Ethernet connector	23
1.8 Fault philosophy.....	23
2. INSTALLATION	26
2.1 Care of Your Product.....	26
2.1.1 Handling	26
2.1.2 Unpacking and Inspection.....	26
2.1.3 Storage.....	26
2.1.4 Cleaning & Maintenance.....	27
2.2 Mechanical Installation Considerations	27
2.2.1 Mounting	27
2.2.2 Cooling	27
2.3 Prime Power Supply & Connection	28
2.3.1 Fuses	28
2.3.2 Earthing.....	29
2.4 Other Interface Connections.....	29
2.4.1 Internal Beacon Receiver L-band Connection.....	29
2.4.2 Internal Beacon Receiver SHF Connection	29
2.4.3 Internal Beacon Receiver Auxiliary Output Connection.....	29
2.4.4 External Beacon Receiver DC Input Connection.....	30
2.4.5 External Reference Input Connection.....	30
2.4.6 UpLink Channel Compensation Connections – In, Out, Bypass	30
2.4.7 Alarms Interface Connection.....	30
2.4.8 Remote Serial Communications Interface (RS-232/RS-485)	31
2.4.9 Redundancy Interface Connector	32
3.2 Setup.....	35
Modify Parameters.....	35
3.1 Home menu	36
3.1.1 Operating displays	36
3.1.1.1 UPC Display	36
3.1.1.2 Rx Level Display Screens	37
3.1.1.2a Internal Beacon Receiver	37
3.1.1.2b External Beacon Receiver.....	37
3.1.1.3 Beacon Video Display Screen (only shown if internal Beacon Receiver is fitted)	37
3.1.2 Status screen	38
3.1.3 Configuration screen.....	38
3.1.3.1 UPC Configure	39
3.1.3.1.2 Calibration	40
3.1.3.1.2.1 Clear Sky Level	40
3.1.3.1.2.2 Clear Sky Offset	40
3.1.3.1.2.3 External Channel.....	41
3.1.3.1.2.4 Fade Limit.....	41
3.1.3.1.2.5 Fade Limit Hysteresis.....	41
.....	46
3.1.3.1.5 Beacon Selection	46
3.1.3.2a Tracking Configuration screen (internal tracking only).....	48
3.1.3.2b External Beacon Configuration screen.....	59
3.1.3.3 EXP Configure.....	61
3.1.3.4 Pilot Configure	62
3.1.3.5 Remote Control	64
3.1.3.5.1 Set remote mode.....	64
3.1.3.5.2 Setup RS485	64

3.1.3.5.3 Setup RS232	64
3.1.3.5.4 Set Protocol	64
3.1.3.5.5 Ethernet (Optional)	64
3.1.3.6 Redundancy	66
3.1.3.6.1 Identifier	66
3.1.3.6.2 Change Over	66
3.1.3.6.3 List Units in System	66
3.1.4 Log	67
3.1.5 Service	67
3.1.5.1 Fan	67
3.1.5.2 Tracking Rx LUT	68
3.2 Setup.....	70
4. REDUNDANCY	72
4.1 1+1 Redundancy (switched)	72
5. REMOTE CONTROL	74
5.1 P7xxx Protocol.....	74
5.2 Remote control version.....	107
5.3 Ethernet remote control (Optional)	108
APPENDIX 1 Terms and conditions of sale	110

CUSTOMER CARE

Contact the Peak Communications sales department for:

- ✚ Product operation, application support or training requests
- ✚ Information for returning or upgrading a product
- ✚ Comments or suggestions on any supplied literature

Contact Information

Peak Communications Ltd
Attention: Sales Department
Unit 1, The Woodvale Centre,
Woodvale Road,
Brighouse
West Yorkshire
HD6 4AB
England
Tel. +44 (0) 1484 714200
Fax +44 (0) 1484 723666
E-mail Sales@peakcom.co.uk

You can also contact us via our website at www.peakcom.co.uk

To return a Peak Communications product for repair:

1. Contact the Peak Communications sales department and request a Return Material Authorisation (RMA) number.
2. You will be required to provide to our sales representative the model number, serial number and a detailed description of the problem.
3. To prevent any damage to the product during shipment we recommend that the unit is returned in its original packaging or if this is not available the packaging used must be of an equal standard.
4. Return the product back to Peak Communications and advise shipment details to sales representative for tracking purposes. (Any shipping charges should be prepaid)

For information regarding our warranty policy see Appendix 1 Terms and conditions of sale.

PRODUCT COMPLIANCE

Safety

To ensure safety of operator the UPC7000 series of Control Units have been designed to comply with the following safety standard;

EN 60950: Safety of information technology equipment, including electrical business machines.

Operation of the equipment in a non-standard manner will invalidate compliance to this standard.

The equipment **MUST BE OPERATED WITH ITS LID ON AT ALL TIMES**. If it is necessary to remove the lid for any purpose then it is essential that the lid is fitted back correctly before normal operation.

DANGEROUS VOLTAGES ARE PRESENT AROUND THE POWER SUPPLY AND PRECAUTIONS MUST BE TAKEN.

EMC

The UPC7000 series of Control Units have been designed to comply with the following standards;

Emissions: EN 55022 Class B; Limits and methods of measurement of radio interference characteristics of Information Technology Equipment.

Immunity EN 50082 Part 1; Generic immunity standard, part 1: Domestic, commercial and light industrial environment.

Damage to the keyboard membrane or mechanical damage to the chassis will also invalidate compliance; please contact the factory under these circumstances for advice on continued operation.

Interfaces to the UPC7000 Series of Control Units must be made with suitably screened connectors and double screened coaxial cable. Data cables must be double screened.

All 'D' type connectors must have grounding fingers on the plug shell to guarantee continuous shielding. The back-shells must comply to the requirements of VDE 0871 and FCC 20708, providing at least 40 dB of attenuation from 30 MHz to 1 GHz.

Installations which do not comply with this requirement will invalidate the EMC specifications.

1. INTRODUCTION

1.1 General product overview & principles of operation

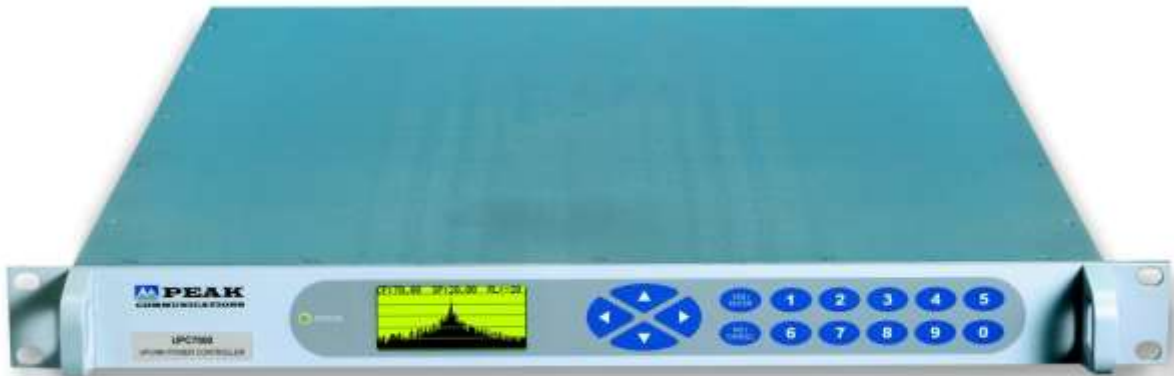

Fig. 1 - UPC7000 L-band Up-Link Power Controller

This Manual covers the installation and operation of the UPC7000 family of Up-Link Power Controller units. A specification for the UPC7000series L band Up-Link Power Controller is incorporated in this manual but is not guaranteed to be the latest, so please visit our website www.peakcom.co.uk for up to date specifications.

The signal transmitted from a satellite earth station is subjected to unwanted signal level variations caused by the natural effects of atmospheric weather conditions (commonly and generally referred to as 'rain fade'), this can be severe in some cases with up to 30dB of variation seen. In order to maintain a constant 'link' power level, this automatic uplink power control unit (UPC) uses the DC output from a beacon receiver, operating on the downlink from the same geostationary satellite as the uplink, to derive 'compensation' settings of variable attenuators that are positioned within the uplink signal path. The Beacon receiver signal is affected in a similar way to the transmitted signal, apart from frequency propagation differences for which the user can make compensation adjustments.

The user is required to calibrate the UPC system in 'clear-sky' conditions which sets the maximum attenuation of the variation range in each uplink path. The attenuators used have a range of 0 to 30dB, but the maximum variation allowed can be 'limited' to avoid saturating the uplink high power amplifier (HPA) by selecting the most appropriate compensation range from the front panel (1, 2, 5, 10 or 30dB typically). The surplus attenuation range can also be used to set individual uplink channels to differing base levels. It is important to note that the UpLink gain/ 'link budget' and overall design should be such that a linear operation is achieved over the full adjustment range of the UPC unit.

For fail-safe conditions, in the event of the Beacon signal being lost or disconnected, the compensation settings will remain fixed at the point of loss and a warning flagged to the user. In the event of an internal equipment fault (includes power disconnection etc.), each compensation channel will revert to a 'bypass' mode (optional to be specified at time of order placement), where an external fixed

attenuator (user selectable) is automatically placed in-circuit instead of the internal variable attenuator. Please note that if this UPC unit is being used in combination with external Peak converters (fitted with attenuators), bypass circuitry is not required and the external attenuator will remain at the previous setting.

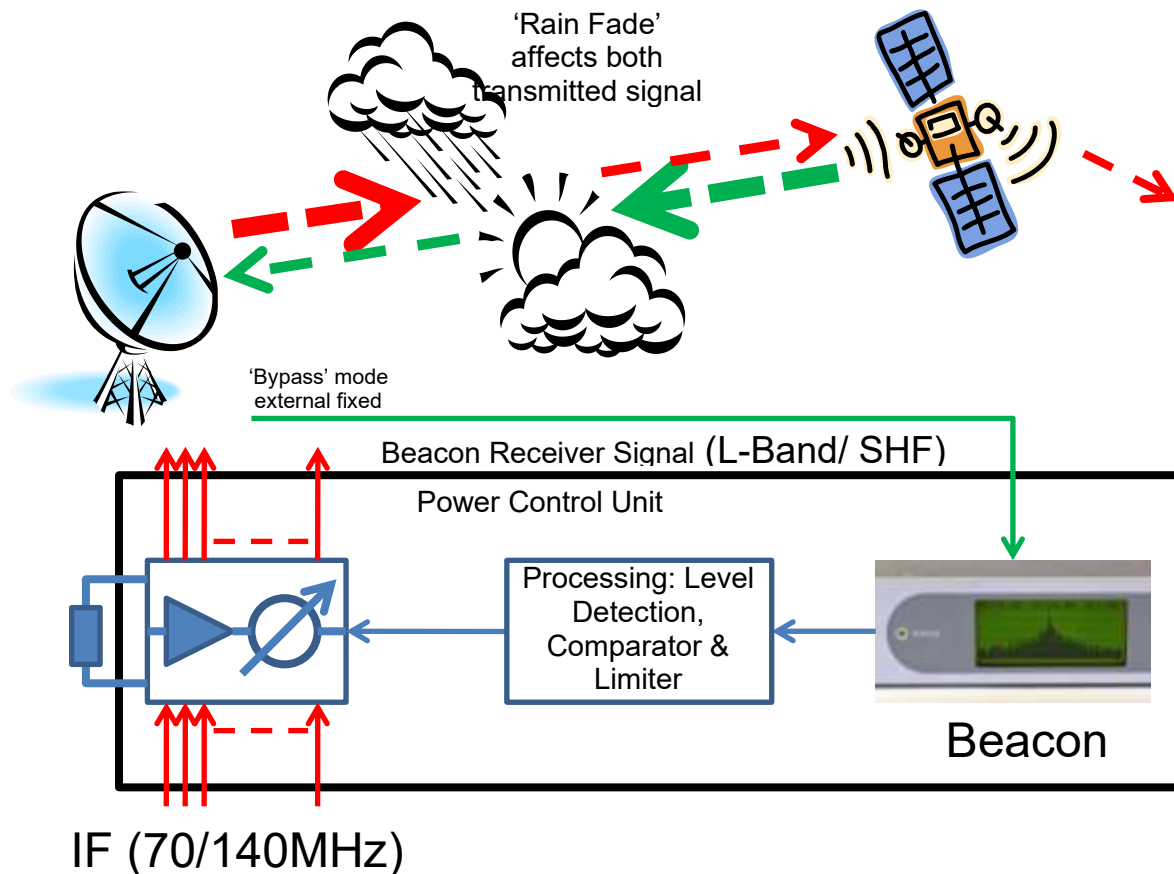

Fig. 2 - Basic RF Block Schematic.

1.2 Functional description

UPC7000 series controllers are housed in a 1U high 19" rack mount chassis and are designed to provide automatic gain adjustment compensation for a number of uplink channels. The compensation and attenuator setting is based on the DC voltage from either an internal or external Beacon Receiver that is proportional to the signal level being received from a geostationary communications satellite (this can be either a dedicated Beacon signal or a looped-back carrier).

The signal levels of a number of uplink channels are adjusted via either internal attenuators (Fig. 3) or the control of external attenuators fitted to Peak agile or BUC frequency converters (Fig. 4). The 1RU chassis supports up to 4 uplink channels, thereafter 'expansion' units are provided to increase to 10-channels and beyond, these are configured as 'slaves' to the main UPC unit.

For units with internal L-Band compensating channels, these units can be provided with a DC & 10MHz pass option. DC & 10MHz are often multiplexed onto L-Band UpLink signals to provide power and an external 'station clock' derived reference signal for Block Up Converter's or Power BUC's (HPA's). If this option has been

ordered and fitted, then the unit is configured to allow these signals through from the UpLink channel input 'In' to the output 'Out' without being affected by the internal circuitry.

The UPC7000 units can provide a high stability 10MHz reference signal and 22.5V DC to power an external Block DownConverter/ LNB via the Beacon Receiver input connection.

The UPC7000 series of converters will interface with the Peak range of redundancy units for N+1 switching, using the CANBUS® interface. For more details please contact the factory.

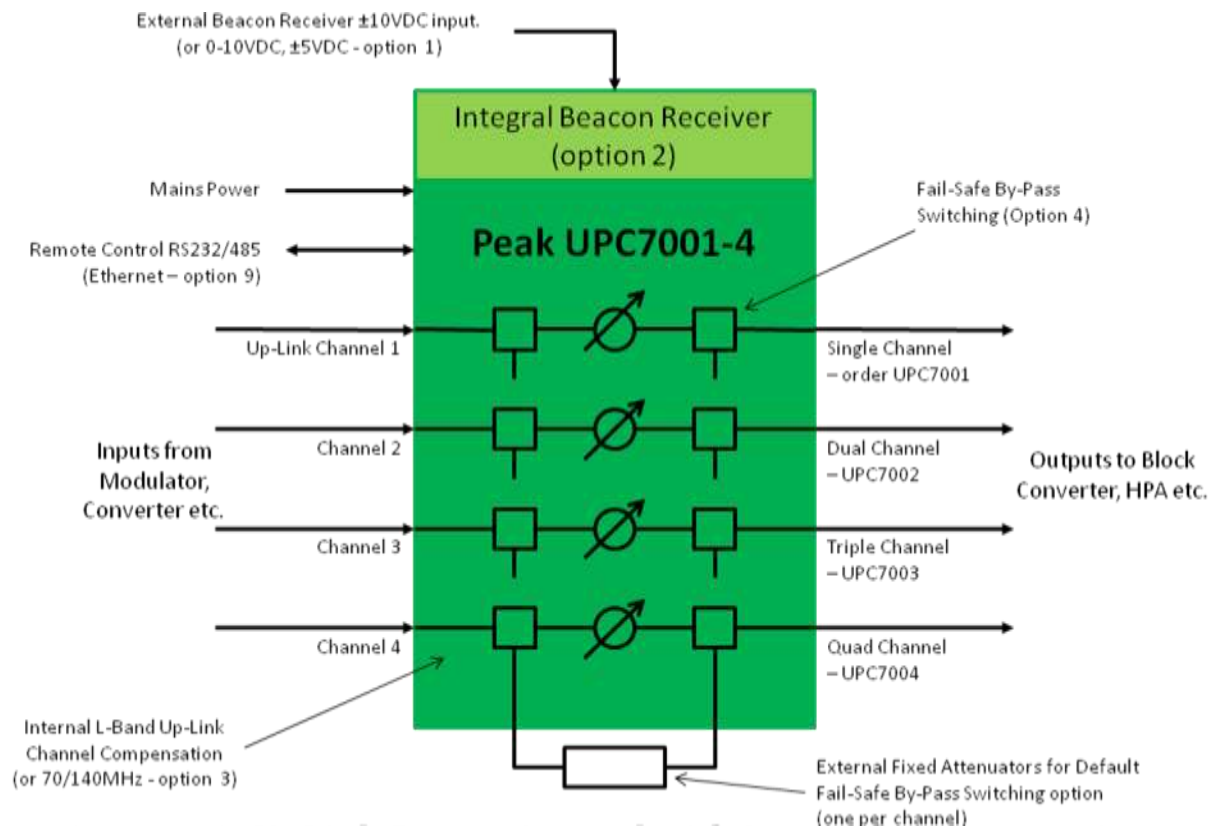

Fig. 3 – UPC shown with Internal Compensating Channels.

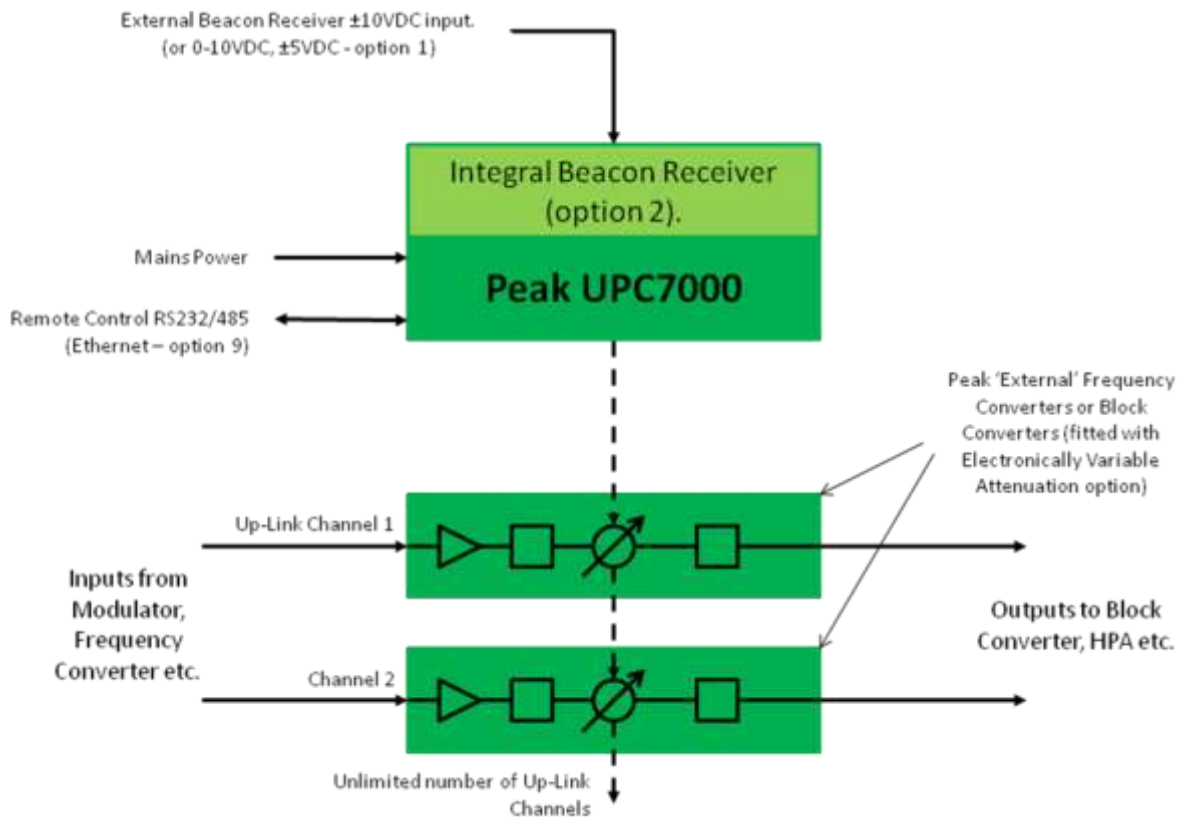

Fig. 4 – UPC shown controlling external Peak converter units.

1.2.1 Internal Beacon Receiver – Functional description & operating suggestions.

Functional Description;

The UPC7000 series when fitted with the internal Beacon Receiver option will down convert an L-Band signal to an IF of $70 \pm 18\text{MHz}$, the signal is then split between the tracking function and the video display function, The tracking function then uses a coherent detector to lock to the 'CW' beacon and measure the power of the beacon signal. The video function uses a detector with switchable IF filters to display the required band on the front panel display allowing the required signal to be conveniently monitored. The display can be used for system fault location, routine maintenance and can be an effective alternative to a fully functional spectrum analyser, which may not be necessary for these tasks.

The units also incorporate a switchable, single sweep digital anti-sideband detector to prevent the unit locking to beacon sidebands (the video function is only available when the ASB function has finished). The unit features a large graphic LCD display, membrane keyboard and menu driven software for control and configuration of the unit. The units have built in 1+1 redundancy control and can be remotely controlled via a RS232/485 port (optional Ethernet is available supporting TCP, SNMP and an internal web-browser function).

The UPC7000 series are fully software controlled; there are no links or switches used to configure the unit. This enables all control and configuration to be programmed either locally or by remote control. All of the configuration parameters

are stored in non-volatile memory that will retain data for a minimum of 5 years with no power applied.

Operating suggestions;

The following are suggested set points to enable the customer to get the best use out of the unit with the minimal of time.

Tracking sweep range of $\pm 50\text{kHz}$.

Sweep time of 5kHz/s .

Log output of 2dB/V .

The Coherent detector operates ideally with a post DownConverter level of between -60dBm to -90dBm , so by using the variable gain of the DownConverter section the optimum level can be achieved i.e. with an expected signal of -100dBm the DownConverter should be set towards its maximum gain of 20dB and with an expected signal of -70dBm the gain should be set towards the minimum of 0dBm .

When the expected signal exceeds -80dBm then it is suggested that the optional video 10dB pad is turned on, to prevent compression of the video section (this does not affect the tracking section).

The ASB function is active for a single sweep when the unit has first locked, the down converted spectrum is swept and monitored for a higher signal and if one is found then the main receiver is forced to check the rest of the spectrum. This results in the unit locking to the highest-level signal in its sweep range. Due to the digital analysis of the bandwidth the ASB will take around 5 minutes to complete a full sweep. It is suggested that when the unit is used on a non-sideband beacon the ASB function should remain off.

1.3 UPC7000 Specifications

This specification is provided to show typical values and explain the parameters involved. The specification may change so please refer to our website www.peakcom.co.uk for the latest up to date specifications.

1.3.1 Input Section

External Beacon Receiver Input;

DC input from an external Beacon receiver unit (Peak PTR50 or other), via a SMA (f), 50Ohm connector on the rear panel. Various DC input ranges are available, as follows;

Standard range	$\pm 10\text{VDC}$
Option 1a	$0-10\text{VDC}$
Option 1b	$\pm 5\text{VDC}$

Internal Beacon Receiver (Optional);

An internal Beacon Receiver is available which accepts an L-Band (SHF input options are available) input signal via an N-Type (f), 50Ohm connection on the rear panel;

Beacon Receiver input frequency and performance;

The following Beacon input frequency ranges are available;

Option 2	L-Band ($925-2150\text{MHz}$) input
Option 2a	C-Band ($3.4-4.2\text{GHz}$, inverted spectrum) input

Option 2b	X-Band (7.25-7.75GHz) input
Option 2c	Ku-Band (10.7-11.7GHz) input
Option 2d	DBS-Band input
Option 2e	Ka-Band (20.2-21.3GHz) input
Return loss	15dB typical
Input Level; Option 2	-70dBm nom -50dBm max -20dBm max aggregate power

A user adjustable L-Band composite input attenuator 0-30dB in 0.5dB steps is included. This will increase the nominal and maximum levels above when used.

Option 2a-2e	-90dBm nom -70dBm max -40dBm max aggregate power
--------------	--

SHF composite input attenuators are available as an option
This will increase the nominal and maximum levels above when used.

Note; an auxiliary ± 10 VDC output is provided to drive other equipment.

Slope	Logarithmic, 0.5dB/V, 2dB/V, 5dB/V & 10dB/V (user selectable from front panel menu)
Connector	BNC (f)
Transfer Characteristics;	
Synthesizer step size	1Hz
Search range	± 20 kHz, ± 50 kHz, ± 100 kHz, ± 200 kHz, ± 500 kHz, user selectable

Tracking Parameters;

PLL noise (IF) BW	2kHz fixed
Threshold lock reacquisition	35dBHz
Average search time	3s (for bandwidth of 2kHz)
Beacon 'display';	Graphical
Resolution Bandwidth	2kHz, 50kHz, 1MHz, user selectable from front panel menu

External reference input;

An external reference input is available via a BNC (f), 50Ohm connect.

Frequency	Factory selectable 5 or 10MHz
Level	0dBm, ± 3 dB
Phase noise	To be better than 50dBc/Hz of output Phase Noise

Internal reference;

An internal back-up reference is provided that automatically takes over if the external reference is either not provided, is disconnected or fails.

Frequency	10MHz
Adjustment	± 1.0 ppm, stepped 0.02ppm
Stability	$< 5 \times 10^{-10}$ over 1s, $< 5 \times 10^{-9}$ per 12 hrs
Ageing	$< 5 \times 10^{-7}$ per year
Temperature stability	$< 5 \times 10^{-8}$ over 0 to 40°C

1.3.2 UPC Section

The **compensation range** is user selectable to allow the automatic variation to be pre-set to +1, +2, +5, +10 or +30dB, the user can set custom ranges if necessary. This minimises the likelihood of accidentally overdriving or saturating the high-power amplifiers in the uplink equipment chain.

The attenuators have a high-resolution **step size** capability of 0.1dB. The operational compensation **step size** is user selectable to 0.1, 0.5, 1 or 2dB.

The **compensation ratio** is applied directly to the compensation calculation and allows the user to make corrections for variations in uplink to downlink attenuation levels. This is user selectable from 0.1 to 10dB and for every 1dB drop in Beacon level, attenuation is reduced according to the above setting value. Setting resolution is to 0.1dB.

Slew Rate; The **Slew rate** sets the maximum rate of change of the compensation applied and allows the user to limit the rate of change. This facility can be enabled/disabled and when enabled, set to the equivalent of between 0.01 & 0.1dB/s, user selectable.

The **Sample period** sets the timeframe over which the measured Beacon Receiver output is averaged before applying the new compensation to the attenuation channels. This can be user settable from 0.2 to 10s.

Example; If the step size is set to 0.5dB, the compensation ratio set to 1.1, the slew rate to 0.1dB/s and the sample period to 5s, the average Beacon power will be taken over a period of 5 seconds, and then if a modified Beacon level is detected, the new attenuation value will be calculated using the compensation ratio and applied to the attenuators at a rate of a single 0.5dB step every 5 seconds.

1.3.3 Output Section

External Peak UpConverter, BUC or Line Amplifiers;

The unit can be provided without internal compensation channels (variable attenuators), in this case the unit can be connected to any Peak P7000series Synthesised/ Agile UpConverter or Peak IBUH series Block Up Converter (with attenuator options fitted) or Peak ILAH series L-Band Line Amplifiers (with attenuator option fitted).

This has the advantage of using attenuation already fitted in the uplink chain and thus simplifies the system design. An attenuator adjustment range is 'reserved' for the UPC function and the attenuators controlled via the Peak CANBUS® Data connection. In this mode of operation, in the event of the loss of Beacon signal, a cable disconnection or a fault on the UPC unit, the attenuator will remain at the previous setting.

Internal Adjustable Attenuators;

The unit can be provided with up to 4 separate internal channels of uplink compensation. For additional channels, an 'expansion' unit is provided which supports up to 10 channels and is 'slaved' to the main UPC unit.

UpLink Signal type;	L-Band (950-2150MHz), SMA (f), 50Ohm
Option 3;	IF 70±18MHz/ 140±36MHz, SMA (f), 50Ohm
1 dB GCP	Output +8dBm typical, +22dBm with option 15
Return loss	15dB typical
Attenuation control	0-30dB, stepped 0.1dB
Gain stability	±0.25dB from 0 to +40deg.C. ±0.1dB per week (constant temp)
Gain flatness	±0.5dB full band (±0.2dB option 3 IF) ±0.2dB across any 36MHz in band

A **fail safe, by-pass** is fitted as standard for each internal channel of compensation, this provides a switching arrangement where the unpowered (default) position routes the UpLink signal through an external fixed attenuator 'pad' fitted on the rear of the unit.

The user would calculate, provide and fit the fixed attenuator 'pads' based on the level of attenuation required in this fail-safe condition, taking into account any offset attenuation entered on the internal attenuators and the likely 'average' conditions to satisfy the link requirements, whilst not over driving the Satellite.

Option 5b is factory supplied external connection cable including a fixed attenuator the value of which is specified by the customer at the time of ordering.

As power is applied to the unit, the compensation channels remain in the 'off-line' mode until the user selects either the 'manual' or 'automatic' mode, at which time the internal switching activates and routes the UpLink signal through the internal attenuation circuitry. This condition remains until a fault is detected on the unit, the power is removed or the compensation channel condition is set back to the 'off' mode. In the case of a temporary loss of power or a fault condition that is rectified, the previous condition is automatically resumed.

Please note that if the UPC unit is being used in combination with external Peak converters (fitted with attenuators), bypass circuitry is not required and the external attenuator will remain at the previous setting.

In the event of the Beacon signal being out of lock or disconnected, the compensation settings will remain fixed at the point of loss and a warning flagged to the user.

Bypass connection	SMA (f), 50Ohm (2 connections per channel)
Bypass Insertion Loss	2dB (plus external pad fixed attenuation value)

A **DC & 10MHz pass-through** option is available for internal L-Band compensation channels. This facility if fitted allows the DC power supply and the 10MHz external reference signal to be passed through the internal compensation circuitry to the external system BUC, without effect in either the off-line (bypass) or on-line modes of operation.

1.3.4 General

Reference frequency	internal 10 MHz frequency trimmed by software
External ref input (option)	factory selectable 5 or 10MHz
Stability	1 second $<5 \times 10^{-11}$
Ageing	$<7.5 \times 10^{-8}$ per year 5×10^{-10} per 12 hrs
Mechanical	Standard 19inch rack mountable, 1RU stainless steel chassis - 534mm deep, weight approx 8kg dependant on options
Environmental Compliance	Operating temperature range 0 to 50°C EMC to EN 55022, part B and EN 50082-1, safety to EN 60950
Power supply	90 to 264VAC, 47-63Hz
Remote Control	RS 232/ RS 485 port
Redundancy features	In-built 1:1 CANBUS® system

1.4 Review of UPC7000 Specification parameters

Input Section

The Uplink Power Control unit as standard includes an external Beacon Receiver DC input, and can also be provided with an internal Beacon Receiver.

1.4.1 External Beacon Receiver

1.4.1.1 External Beacon Receiver Input

DC voltage is proportional to the received signal strength provided by an external Beacon Receiver. As standard the voltage range is -10 to $+10$ VDC, but other ranges can be changed via an appropriate front panel menu option.

The user is required to input the slope (dB/V) for the external Beacon Receiver being used. An offset function allows the UPC unit to calculate the absolute received level.

The user can input this information if known.

1.4.2 Internal Beacon Receiver DownConverter section

1.4.2.1 DownConverter Input

925 MHz to 2150MHz full L-Band down conversion the selected frequency is passed to the Tracking section with a bandwidth of ± 2.5 MHz and to the Video section with ± 25 MHz

1.4.2.2 DownConverter resolution

1KHz Tracking frequency step size.

1.4.2.3 DownConverter Conversion Gain

Adjustable down conversion gain is available for best noise performance and dynamic range.

0 to 20dB \pm stepped 0.1dB

The gain of the converter can be set to have no gain at 0dB or a gain of 20dB. The finite gain set is specified to be within 2dB of the setting and the step size is 0.1dB. The tolerance of the step size is not specified but should not exceed 0.05dB per step.

1.4.2.4 Auxiliary DC and 22KHz tone

Selectable regulated voltage 13-15V in steps and 18 to 20V in steps @ 0.5 Amp, software switchable on / off

This facility is used for driving an external SHF block down converter or an LNB. This voltage is integrated with the L-Band signal (and 10MHz). The current is limited and protected.

The 22KHz tone function can be enabled and disabled via the front panel

1.4.2.5 10MHz reference output

0dBm nominal, software switchable

This facility is used for stabilising the output frequency of an external L-Band to SHF Block DownConverter. This signal is integrated with the L-Band output signal. An outdoor BDC/LNB will drift in frequency due to ambient temperature changes causing changes to the BDC locking crystal inside the unit. Inside Peak BDC's the facility is made to pick up the 10MHz locking signal sent by the UPC7000 and lock to the internal crystal. With the BDC locked to the indoor unit the stability of the BDC unit is as good as the internal UPC7000 crystal. With very long cables caution should be taken not to attenuate the 10MHz (and DC) too much.

1.4.3 Internal Beacon Receiver Tracking Section

1.4.3.1 Tracking Output

DC voltage proportional to the received signal strength at the required dB/V and offset using the DC offset menu to between $-10V$ to $+10V$ DC

1.4.3.2 Tracking Level

Maximum Tracking signal level is -20dBm when input composite attenuator is at 30dB and downconverter gain is 0dB , the minimum is the determined by the noise level on the carrier though the unit will become nonlinear below -110dBm at these levels the composite input attenuator shall be set to minimum and the downconverter gain to full.

1.4.3.3 Sweep Range

5 user selectable sweep widths to allow for drifts on the required signal whilst searching it is suggested to leave on the narrower settings as this will speed up acquisition of lock. The settings available are $\pm 20\text{kHz}$ $\pm 50\text{kHz}$ $\pm 100\text{kHz}$ $\pm 200\text{kHz}$ $\pm 500\text{kHz}$. It is suggested to use the narrowest setting if possible. Use of non 10MHz referenced LNB's may require the use of a wider sweep width, to allow lock acquisition.

1.4.3.4 Sweep Rate

Up to 8 user selectable sweep rates allow the user the choice to speed up the acquisition of lock. The user must be aware that the lower the signal to noise ratio the slower the sweep rate needs to be to guarantee lock detection. The settings available are; 2.5kHz/s , 5kHz/s on standard units, on fast acquisition units the extra sweep rates are; 10kHz/s , 20kHz/s , 40kHz/s , 80kHz/s , 120kHz/s , 240kHz/s . It is suggested to use 5kHz/s as a starting point.

1.4.3.5 Post Detection Time Constant

This is the smoothing on the DC output and is factory set to the value of 150ms .

1.4.3.6 Log Output Scale

4 User selectable settings for the DC Logarithmic output voltage. The settings available are 0.5dB/V , 1dB/V , 2dB/V , 5dB/V & 10dB/V .

1.4.3.7 DC Output Adjustment

User adjustable offset of the Log output adjustable to $0V$ DC for input power levels from -20dBm to -100dBm at 2dB/V .

1.4.3.8 PLL Noise Bandwidth

This is factory set to 2kHz .

1.4.3.9 Threshold for Reacquisition

A unit with option 11 unit will lock with a threshold of 43dB/Hz (unit must be on slowest sweep rate setting for these figures). A standard unit will acquire lock at 35dB/Hz at the slowest sweep speed.

1.4.3.10 ASB Sweep Rate

The ASB when enabled will analyse the tracking band searching for a higher signal and if one is detected will enable the tracking lock circuit to release lock and search for this higher signal. The sweep rate on the ASB is around 80Hz/s .

1.4.3.11 ASB Threshold

When the ASB is searching it is looking for a signal which is at least 3dB higher than the current locked signal level

1.4.4 Internal Beacon Receiver Video Section

1.4.4.1 Video Input

Selected Beacon frequency $\pm 25\text{MHz}$ (lower limit of 925MHz upper limit 2150MHz) is available to display on the front panel. The minimum setting for span is set by the resolution i.e. with wide res the display can be 160 pixels of $(6\text{kHz}/2) = 480\text{kHz}$ and with the narrow a minimum span of 80kHz is available.

1.4.4.2 Video Resolution

The detector has a bandwidth of 6kHz

1.4.4.3 Vertical Resolution

The display vertically axis is set to 10dB/division.

1.4.4.4 Video Section Attenuator

It is Possible to switch in a 10dB pad to allow measurements to be better made if the unit has a high aggregate input level.

1.4.4.5 Reference frequency

Internal 10MHz frequency, software trimmed.

Uses a high grade OCXO at 10MHz

External reference input: Will accept either 5 or 10MHz.

Stability; $< 5 \times 10^{-10}$ / second, ageing $< 5 \times 10^{-7}$ / year, $< 5 \times 10^{-9}$ / 24 hrs, $< 5 \times 10^{-8}$ over 0 to +50deg.C.

1.4.5 UPC Section

1.4.5.1 Compensation Range

user selectable, with pre-set ranges +1dB, +2dB, +5dB, +10dB & +30dB.

Sets the range of automatic adjustment

Typically, in tropical areas 'rain fade' is at its worst and can increase by up to 30dB, so the higher ranges would be required, but in more benign areas lower ranges would be more suitable. Many other factors have an effect, so the user should for each link study, test and set the range to ensure that worst case conditions are met. Statistics are readily available for regions throughout the world and will give the user guidance for the most suitable settings to use.

1.4.5.2 Step Size.

0.1dB, 0.2dB, 0.5dB, 1dB & 2dB, user selectable

Although the variable attenuator incorporated within the design has a high resolution of 0.1dB, the resolution can be reduced by the user. This gives the attenuation increments and generally the smaller the step size, the more often the compensation will be automatically adjusted for changes in 'rain fade'. With a larger step size the compensation is coarser and will generally not update as regularly for the same change in conditions.

1.4.5.3 Compensation ratio.

0.1 to 10dB, user selectable.

For every 1dB drop in the Beacon level, the attenuation is reduced according to this set value. In this way, a 1dB setting provides a ratio of 1:1 and corresponds to a direct correlation between the DownLink (Beacon) and transmitted signal 'rain fade'. Generally, UpLink and DownLink 'rain fade' characteristics are similar, however

differences based mainly on propagation at the different frequencies, but also other factors, have an effect. The user should for each link study, test and set the ratio to best replicate the relationship between the Uplink and the Downlink characteristics. If unknown at the time of commissioning, this can be easily modified afterwards when more information is known about the likely link conditions.

1.4.5.4 Slew Rate.

0.01 to 0.1dB/s, (1dB/10s to 1dB/100s) user selectable. This facility can be disabled.

Controls the maximum rate of change of the compensating attenuators

If the Beacon level suddenly dropped by 1dB and the slew rate is set to 0.1dB/s, it would take 10 seconds to complete the automatic compensation adjustment (assuming the compensation ratio to be 1:1 and the sampling period to be low enough to allow this rate of change).

1.4.5.5 Sample Period.

0.2 to 10s, user selectable.

Sets the time period over which the Beacon output signal is averaged before the compensation is calculated and applied to the attenuator settings. This does directly affect the update rate and can, depending on the settings, override the slew rate setting.

1.4.6 Output Section

1.4.6.1 Internal UpLink Channel Compensation Circuit Input.

Either L-Band 950 to 2150MHz or 70/140MHz based IF signal.

Fitted on the UPC7001, 2, 3, 4 UpLink Power controller units (with internal UpLink compensation)

Connected in the UpLink equipment chain, typically to the Modem (Modulator) TX L-Band or IF (70/140MHz) output or to the Agile Frequency Converter L-Band output.

1.4.6.2 Internal UpLink Channel Compensation Circuit Output.

Either L-Band 950 to 2150MHz or 70/140MHz based IF signal.

Fitted on the UPC7001, 2, 3, 4 UpLink Power controller units (with internal UpLink compensation)

Connected in the UpLink equipment chain, typically to the agile frequency converter 70/140MHz input, the L-Band Block Converter input or the Power BUC (HPA) L-Band input

1.4.6.3 Internal UpLink Channel Compensation Circuit Bypass Connections.

Either L-Band 950 to 2150MHz or 70/140MHz based IF signal.

These connections (2off), allow the external connection of a fixed attenuator (pad). The pad is automatically switched in to the RF circuit in place of the internal attenuator in the event of a problem within the UPC unit, the removal of the prime power supply to the UPC or by the user selecting the 'off-line' mode for the channel in question. This provides a 'fail safe' condition, and if the pad value is chosen correctly will avoid over driving the Satellite in the event of an equipment problem.

1.4.6.4 1dB Gain Compression Point.

The 1dB compression point is a finite point in the power scale where a 1dB input only gives 0.5dB increase in power. Note; the values specified are for total composite power and are not single carrier. Standard channels output compression is +8dBm, with option 15 taking the level to +22dBm, however this option removes the gain compensation in the attenuator circuitry, this results in an increase of insertion loss to around 4dB nominal. Option 15 allows higher power through the UPC channel for use with multiple signals simultaneously or for expected high power signals without compression degradation.

1.4.6.5 Insertion Loss and Attenuation.

Insertion Loss; 1dB (with minimum attenuation set)

Attenuation; 0-30dB, stepped 0.1dB

For units with internal compensation channels, each channel includes amplification to overcome some of the loss associated with the internal RF circuitry. With maximum attenuation set, the Loss of the unit is approximately 31dB or with minimum attenuation 1dB. The attenuation set is specified to be within 2dB of the setting and the step size is 0.1dB. The tolerance of the step size is not specified but should not exceed 0.05dB per step.

1.4.6.6 Gain Flatness.

± 0.5 dB full band, ± 0.2 dB, across any 36MHz in band

1.5 Mechanical description

The UPC7000 Series of converters are housed in a 19-inch 1U high chassis, suitable for rack mounting. It is 534 mm deep and may be fitted with rack slides if required. Figure 2 shows views of the front and rear panels of the UPC7000 series Up-Link Power Controllers.

On the front of the unit is the keyboard, LCD display and LED indicators. The operator is prompted by messages displayed on the LCD to enter data via the keyboard. In this way the UPC7000 may be configured for use, and the set up changed, if necessary. The LEDs provide a quick visual indication of the operational status of the unit.

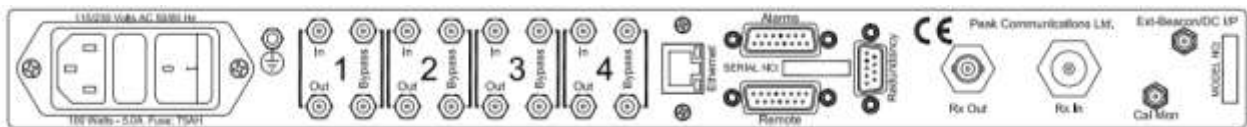
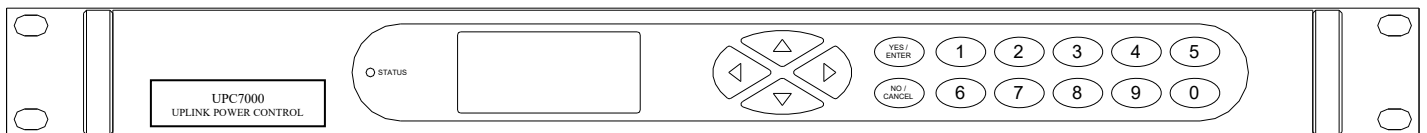

Rear panel with integral beacon receiver option

Fig. 5 – front & rear panel views

1.6 Front panel description

Keyboard

The keyboard is of the membrane type and is an integral part of the front panel assembly. The front panel overlay and is completely sealed against penetration of liquids but caution should be taken especially with solvents which may damage the front screen.

There are 16 keys in total; number keys in the range 0 to 9, YES/ENTER and NO/CANCEL and a 4-way arrow block of keys

LCD display

The backlit display is a graphic display and characters are scaled to incorporate as much information as possible on the screen. It provides detailed information about the status and configuration of the unit, and when appropriate, prompts the user to enter data via the keypad.

LED Indicator

Only one tricolour LED is present marked STATUS. This shows GREEN when the unit is OK, RED when an internal fault is present and AMBER when in STANDBY (Redundancy operation)

1.7 Rear panel description

All of the connectors necessary for the user to interface the UPC7000 series to other equipment are located at the rear of the unit. Depending on the model the connections may include the following;

External Beacon Receiver Input; labelled 'External Beacon DC input', always an SMA(f) connector.

Alarms, Remote Control, Redundancy; all 'D' type connections
EC mains power connector/switch/fuse.

Units with internal Beacon receiver;

Beacon Receiver Output; labelled 'RX Out', always a BNC(f) connector.

Beacon Receiver Input; labelled 'RX In', always an N-Type(f) connector.

The UPC7000 series of converters are designed to operate from an AC mains supply, 90-264VAC, 47-63Hz. The Input connector incorporates a mains switch and 2 input fuses. Access to the fuses is also provided under the removable cover.

ALWAYS REPLACE THE FUSE WITH ONE OF THE SAME TYPE AND RATING.

1.7.1 Chassis Earth stud

To provide the correct level of safety to the operator this must be connected to a suitable safety earth provided in the rack installation. See the Safety and EMC comments in section 1.

1.7.2 Rx In

On units fitted with an internal Beacon receiver option, this is a 50Ohm, N-type (f) connector.

For the L-Band Beacon Receiver, the input frequency should be in the range 925 to 2150MHz or for units fitted with the optional SHF input (internal LNB), the frequency range will be as stated on the datasheet.

1.7.3 Rx Out

On units fitted with an internal Beacon receiver option, this is a 50Ohm, BNC (f) connector and it provides an auxiliary Beacon receiver DC output to drive other external equipment. CAUTION; DC is present on this connector at all times within the range of -10V to +10V.

1.7.4 Ext Ref.

Optionally fitted the UPC7000 series of converters this is the input for the 10MHz station clock input. The internal reference is 'locked' to the external reference. Connector type is 50Ohm SMA (f).

1.7.5 UpLink Channel Compensation 'In'.

On the UPC7001, 2, 3, 4 UpLink Power controller units (with internal UpLink compensation), these connections are used for the UpLink chain input and can be either L-Band or IF (70/140MHz) depending upon the product options chosen at time of ordering.

Connector type is 50Ohm SMA female.

1.7.6 UpLink Channel Compensation 'Out'.

On the UPC7001, 2, 3, 4 UpLink Power controller units (with internal UpLink compensation), these connections are used for the UpLink chain output and can be either L-Band or IF (70/140MHz) depending upon the product options chosen at time of ordering.

Connector type is 50Ohm SMA (f).

1.7.7 UpLink Channel Compensation 'Bypass'.

On the UPC7001, 2, 3, 4 UpLink Power controller units (with internal UpLink compensation), these connections (2off) allow the external connection of a fixed attenuator (pad). The pad is automatically switched in to the RF circuit in place of the internal attenuator in the event of a problem within the UPC unit, or the loss of the Beacon signal. This provides a 'fail safe' condition and if the pad value is chosen correctly will avoid over driving the Satellite in the event of an equipment problem or the loss of the Beacon signal.

Connector type is 50Ohm SMA (f).

1.7.8 Alarms connector

This is a 15-pin male 'D' type connector, which provides access to the various form 'C' relay contacts which indicate alarm conditions.

1.7.9 RS232/RS485 Remote Control connector

This is a 15-pin female 'D' type connector. The UPC7000 provides both an RS232 port for remote control, and an RS485 port for 'multi-drop' applications.

1.7.10 Redundancy

This is a 9-pin male 'D' type connector. The UPC7000 has a built-in 1+1 redundancy controller. A pair of UPC7000 units is required for correct operation plus a P1000 series switching unit.

1.7.11 Ethernet connector

This is an IEEE802.3 standard connector and is fitted to the rear panel if the Ethernet option is chosen at the time of order placement.

1.8 Fault philosophy

Fault conditions are divided into two categories;

- a) MAIN UNIT COMMON FAULTS; Faults with internal items that on a UPC7000 are common to all sections of the unit (Main power supply assembly etc).
- b) DEVICE SPECIFIC FAULTS; Faults that are specific to the Tracking section or DownConverter or video assembly. These can include external fault inputs.

Most faults as shown below activate the summary ALARM; this will force a change-over if used in a normal redundant system.

The only fault that does not cause the unit to go into ALARM is the 'External Mute'. All faults shown below are reported on the front panel LCD and turn the tri-colour fault LED to red.

- Green – No faults
- Amber – Unit in standby
- Red – Fault condition

The MUTED column shows if the output is muted when the ALARM is active.

HARDWARE ALARMS:

Alarm Type	Fault Name	Unit Fault#1	
		#1	#2
UNIT	" +5V Fault"	YES	YES
	" +15V Fault"	YES	YES
	" -15V Fault"	YES	YES
	"Primary DC Fault"	YES	YES
	"Temp Outside Range"	YES	YES
	"Humidity > Range"	YES	YES
	"Ext. Ref Unlocked"	YES	YES
	"100MHz Fault"	YES	YES
	"Coax Switch Fault"	YES	YES
PSU	"PSU 1/2 Voltage Fault"	YES	YES
	"PSU 1/2 Missing Fault"	YES	YES
DEVICE	"Block Current Fault"	YES	NO
	" +3v Fault"	YES	NO
	"DC Feed Fault"	YES	NO
	" +5V Fault"	YES	NO
	"1 st LO Fault"	YES	NO
	"2 nd LO Fault"	YES	NO
	"Out Of Lock"	YES	NO
	"SHF Fault"	YES	NO
	"External Alarm"	YES	NO
	"External Mute"	YES	NO
UPC	"ASB"	YES	NO
	"Clear Sky Level Too Low"	NO	YES
	"Atten. Range Exceeded"	NO	YES
	"Fade Limit Passed"	NO	YES
	"Missing Ext. Alarms"	NO	YES
UPC (Ext Beacon)	"Channel [X] Coax Bypass" ^{#2}	NO	YES
	"Out Of Lock"	NO	YES
	"Input Voltage Too Low"	NO	YES
EXP	"Input Voltage Too High"	NO	YES
	" +5V Fault"	NO	YES
	" +15V Fault"	NO	YES
	"Coax Switch Fault"	NO	YES
	"PSU Combo Fault"	NO	YES
	"PSU 1 Fault"	NO	YES
EXP (Ext Channel)	"PSU 2 Fault"	NO	YES
	"[Y] : Comms Fault" ^{#3}	NO	YES
	"[Y] : PSU Fault" ^{#3}	NO	YES
	"[Y] : RF Fault" ^{#3}	NO	YES
PILOT	"[Y] : Coax Bypass Fault" ^{#3}	NO	YES
	"Comms Fault"	NO	YES
	"Out of Lock"	NO	YES

Note #1 : See 2.4.7 Alarms Interface Connection
 Note #2 : [X] External UPC Channels 1 to 16 max.
 Note #3 : [Y] External EXP Channels 1 to 10 max.

LOG ONLY ALARMS:

Alarm Type	Fault Name
LOG	"LOG Cleared"
	"Power ON"
	"Watchdog Reset"
	"Auto Switch Over"
	"Manual Switch Over"
ETHERNET	"Ethernet Fault"

2. INSTALLATION

2.1 Care of Your Product

2.1.1 Handling

Single products, when fully packaged for transport can weigh in excess of 12kg's. When multiple Converters are to be delivered at the same time, to the same customer, occasionally two Converters are packaged in the same outer carton, the overall weight can then exceed 20kg's. Care must be taken when attempting to lift or carry these packages.

The shipping carton is qualified for transit of these products and has been used successfully for many years. It will protect against shock and vibration encountered during normal carrier transportation.

PLEASE RETAIN ALL PACKING MATERIALS, including the foam insets. Should the unit need to be returned, return to the address on the front of the manual USING THE ORIGINAL PACKING CARTON, unless it has been seriously damaged.

Avoid subjecting the packaged or unpackaged product to severe shocks.

2.1.2 Unpacking and Inspection

When the product is first received, the outer pack should be inspected for signs of damage. If damage to the outer pack is evident, contact the Carrier immediately and submit a damage report. The equipment should then be removed and inspected for signs of damage, retaining all packing materials. Any visible signs of damage to the equipment should be reported immediately to Peak Communications (electronic photographs of the pack and equipment can help with any subsequent insurance claims). If the equipment appears undamaged, it should be tested for correct operation and again any abnormalities reported to Peak Communications.

When first removing the product from its transit pack, take care to retain all documentation and associated hardware. These products are typically provided with the following items;

- UPC7000 series product.
- Operation manual.
- Test results.
- Mains lead (suitable for use in country of operation).
- Spares kit.

If you suspect that any item is missing, please contact Peak Communications immediately.

2.1.3 Storage

Store the product in the normal horizontal orientation, in its outer carton until it is required for use. Do not use the products to support the weight of other items whilst in storage.

Storage temperature range is typically from -40°C to +80°C, avoid exceeding these extremes otherwise damage may result.

Avoid exposing the packaged or unpackaged product to extremes of humidity or moisture (including condensation). In the event that this does occur, the product

should be left at room temperature for in excess of 5 hours to dry naturally before application of prime power.

2.1.4 Cleaning & Maintenance

The product is designed to be installed and operated in a clean air environment. Apart from occasional cleaning of the front panel, no regular cleaning &/or maintenance is necessary.

Always ensure that the product is off-air and that the mains supply is isolated before attempting to clean the front panel. Cleaning of the front panel can be accomplished with a damp cloth. Do not use excessive amounts of water & do not use detergents or other cleaning agents without first consulting Peak Communications.

2.2 Mechanical Installation Considerations

2.2.1 Mounting

This product has been designed to mount in a standard IEC 19-inch racking system, but can also be used free standing or mounted in a standard IEC flight case.

The product is of standard 1U height (1.75 inch) and depth of 534mm (21 inches). Standard connector mating parts with cable bend radii, plus space to uncouple connectors, can add a further 80mm (3.15Inches) to this depth & should be considered when designing the installation.

The product is provided with standard 19-inch rack front panel fixing points, however these should not be solely relied upon to support the entire weight of the unit. Four (two on each side) additional M3 mounting points are provided along the sides of the unit, these can be used to support the unit from rack slide rails or other side support mechanisms, alternatively shelving brackets can be used to provide rest support for the units.

Cooling slots are provided on the sides of the unit, care should be taken to avoid blocking these when designing the installation (see Cooling section below).

When several products are to be mounted on top of one another in a rack system, they should not be stacked without individual support. Stacking of units without adequate mechanical support and isolation can degrade microphonic performance of the overall system and hamper maintenance activities.

2.2.2 Cooling

These products dissipate <100W internally and contain an internal forced air cooling system. Air intake and exhaust apertures are provided on the side panels of the chassis, care should be taken to avoid blocking these when designing the installation

Although these products have been designed to operate with a full rack packing density in an ambient of 50°C, for operational reasons it may be necessary to allow extra space if the unit is sandwiched between two longer chassis, or if the rack ambient increases above 50 degrees C. This will be necessary if adjacent equipment

transfer significant heat to the Converter surfaces, through either conduction or convection.

A thermal sensor is fitted to the unit which provides an over temperature alarm

2.3 Prime Power Supply & Connection

The safety notes provided in the product compliance section of this handbook should be read before connecting this product to the mains supply.

This product can be operated from mains supplies of 100-132V a.c. or 200-230V AC (50/60Hz), the appropriate voltage range is automatically selected by the unit and requires no user intervention. The IEC standard mains inlet on the rear of the unit includes a double pole switch.

The typical power requirement of these units is <100W.

The equipment is classified in EN 60950 as 'pluggable equipment, class A' for connection to the mains supply, as such it is provided with a mains inlet cord suitable for use in the country of operation. In normal circumstances this will be of an adequate length for installation in the rack. If the mains cord proves to be too short, then any replacement must have a similar fuse type (if fitted) and be manufactured to similar specifications: check for HAR, BASEC or HOXXX-X ratings on the cable. The connector ends should be marked with one of the following: BS1636A (UK free plug 13 amp); BSI, VDE, NF-USE, UL, CSA, OVE, CEBEC, NEMKO, DEMKO, SETI, IMQ, SEV and KEMA-KEUR for the IEC 6 Amp free socket. Schuko and north American free plugs must have similar markings.

The installation of the equipment and the connection to the mains supply must be made in compliance to local or national wiring regulations for a category II impulse over voltage installation. The positioning of the equipment must be such that the mains supply socket outlet for the equipment should be near the equipment and easily accessible or that there should be another suitable means of disconnection from the mains supply.

2.3.1 Fuses

The equipment is provided with short circuit fuse protection of both the Live and Neutral conductors, both fuses must be functional before the unit will operate. The fuses are accessible from the rear of the unit and are fitted into the IEC mains inlet. To check or replace a fuse, switch off and isolate the mains supply before removing the fuse cover. If a replacement fuse is required, then an equivalent type and rating must be used. The fuse size is 5 x 20 mm, rated at 5A anti-surge (T5A).

2.3.2 Earthing

The equipment is designed to operate from a TN type power supply system as specified in EN 60950. This is a system that has separate earth, line and neutral conductors. The equipment is not designed to operate with an IT power system which has no direct connection to earth.

An external protective earth, providing protection against RF and transient currents, should be connected between the rear panel earth stud (adjacent to the prime power inlet point and fitted with an M4 nut) and a local system earth point.

2.4 Other Interface Connections

2.4.1 Internal Beacon Receiver L-band Connection

For units fitted with an internal L-Band Beacon Receiver option, this connection is provided on the rear panel and has the following characteristics;

Converter Type	Connection Type	Panel Label	Impedance
Internal Beacon Receiver only.	N-type (F)	Rx In	50Ω

The use of high quality cables and connectors for L-band signals is strongly recommended. Cables and connectors should be rated for operation up to 2200MHz. Care should be taken when handling these cables, avoiding stress to connections, tight bend radii and damage from sharp objects, all of which can degrade system performance.

These connections can also be used to interface the 10 MHz reference signal (at a nominal 0dBm level) the DC power (up to 20.5V @ 0.5A) and a 22KHz tone to the external Block DownConverter.

2.4.2 Internal Beacon Receiver SHF Connection

For units fitted with an internal Beacon Receiver with SHF input option, this connection is provided on the rear panel and has the following characteristics;

Converter Type	Connection Type	Panel Label	Impedance
Internal Beacon Receiver only.	N-type (F)	Rx In	50Ω

The use of high quality cables and connectors for SHF signals is strongly recommended. Cables and connectors should be rated for the frequency of operation. Care should be taken when handling these cables, avoiding stress to connections, tight bend radii and damage from sharp objects, all of which can degrade system performance.

2.4.3 Internal Beacon Receiver Auxiliary Output Connection

For units fitted with an internal Beacon Receiver, this connection is provided on the rear panel and has the following characteristics;

Converter Type	Connection Type	Panel Label	Impedance	Notes.
Internal Beacon Receiver only.	BNC (F)	Rx Out	0Ω	5mA max

2.4.4 External Beacon Receiver DC Input Connection

This connection is provided on the rear panel and has the following characteristics;

Converter Type	Connection Type	Panel Label	Impedance	Notes.
ALL UPC	SMA (F)	External Beacon DC Input	1MΩ	DC.

2.4.5 External Reference Input Connection

For units with an internal Beacon receiver, this connection is provided on the rear panel and has the following characteristics;

Converter Type	Connection Type	Panel Label	Impedance	Notes.
Optional.	BNC (F)	Ext Ref.	50Ω	Accepts 5 or 10MHz.

2.4.6 UpLink Channel Compensation Connections – In, Out, Bypass

For units with internal UpLink compensation channels, these connections are provided on the rear panel and have the following characteristics;

Converter Type	Connection Type	Panel Label	Impedance	Notes.
UPC7001, 2, 3, 4	SMA (F)	In	50Ω	UpLink chain input.
UPC7001, 2, 3, 4	SMA (F)	Out	50Ω	UpLink chain output.
UPC7001, 2, 3, 4	2x SMA (F)	Bypass	50Ω	External 'Bypass' Pad.

2.4.7 Alarms Interface Connection

This is provided on the rear panel and is a standard 'D' type 15-pin (M). The connections provide access to the various form 'C' relay contacts which indicate alarm conditions.

If an external Beacon receiver is connected, an appropriate fault output alarm can be connected to the 'Ext. Beacon Lock Input' connection of the UPC 'Alarms Interface' connector pin 10. This signal when connected to ground will be used to trigger the attenuator settings to be maintained at the previous level and ignore any Beacon Receiver signal changes until the alarm pin is open circuit.

A pin configuration is given below;

Unit fault (1) COM	1	9	Unit fault (1) N/O
Unit fault (1) N/C	2	10	Ext. Beacon Lock Input.
Ext. Mute (1)	3	11	Ext. Alarm (1)
Unit fault (2) COM	4	12	Unit fault (2) N/O
Unit fault (2) N/C	5	13	Not used
*** Ext. Beacon Lock Input (2)	6	14	Not used
Not used	7	15	GROUND
** Summary Alarm	8		

Note: N/O indicates 'normally open' in

the non-fail state, with STATUS LED Green.

Unit fault (1) is used for the external or internal beacon receiver.

Unit fault (2) is used for the UPC faults and EXP faults

If there is an overall unit fault then both relays are triggered.

** If option 15SN is fitted then the Summary Alarm pin is available, otherwise it is not. When available this pin is a dry relay contact, which is connected to GROUND when the unit is OK, or open contact when not, i.e. N/C.

*** if option 17SJ is fitted then an extra Ext. Beacon Input is available and hence there is an extra Ex.t Beacon Lock input to match.

2.4.8 Remote Serial Communications Interface (RS-232/RS-485)

This is provided on the rear panel and is a standard 'D' type 15-pin (F). The units provide both an RS232 port for simple two-way remote control, and an RS485 port for asynchronous, 'multi-drop' remote control applications.

A pin configuration is given below;

When this product serial	RS485 Rx +	1	9	RS485 Rx -	using with the
	RS485 Tx +	2	10	RS485 Tx -	
	Not used	3	11	Not used	
	Not used	4	12	Not used	
	Not used	5	13	Not used	
	Not used	6	14	GROUND	
	RS232 Rx In	7	15	RS232 Tx Out	
	Not used	8			

communications interface, a 120Ω bus termination should be fitted externally between the Rx + (pin 1) and Rx – (pin 9) connections of the 15-way 'remote' connector. If used in conjunction with other equipment on a multi-drop system, the bus termination is only required on one unit, typically the furthest from the master device.

A screened cable, terminated to the back-shell of the 'remote' connector should be used to prevent RF interference from adversely affecting operation. When connecting the cable screen to the back-shell, ideally a full 360° contact should be made.

For short cable runs (up to 10m), a cable containing a twin twisted pair conductor arrangement is ideal. Typical conductor characteristics would be size 24 AWG, screened with an overall tinned copper braid. For cable runs above 10m, an insulated signal return connection should also be made.

2.4.9 Redundancy Interface Connector

This is provided on the rear panel and is a standard 'D' type 9-pin (M).

The redundancy interface is a standard feature of these units and can be easily configured so that the converters communicate with each other for 1+1 redundancy systems. The units communicate using the CANBUS® interface system.

A pin configuration is given below;

	Not used	1	6	GND	
	CANBUS® Low	2	7	CANBUS® High	
This is also connector used to an EXP expansion unit to the UPC.	GND	3	8	Tell back A	the that is attached
	Power A	4	9	Tell back B	
	Power B	5			

There needs to be 120R termination resistors between the CANBUS® High and CANBUS® Low pins on both ends of the redundancy cable ie. between pins 2 & 7 on the above connections (both ends).

3. EQUIPMENT OPERATION

The UPC7000 series units fitted with Beacon receiver options are predominantly L-Band based and have additional features for integration with external SHF LNB's/ BDC's.

A typical simple UpLink Power Control system incorporating a UPC7000 series unit could consist of a UPC7000 fitted with an internal Beacon Receiver, connected directly to a remote outdoor LNB or Block Down converter (although the unit can be fitted with a BDC as an option). The UPC7000 series unit powers and controls the external LNB/Block converter by supplying DC Power and a Locking frequency for the internal oscillator. The UPC7000 series can monitor the alarm status of the Block converter to give the operator indication of the state of the outdoor unit. In these situations, the DC and 10MHz signals can be switched on and off and the frequency on the UPC7000 unit can be set to include the frequency of the remote Block converter so an SHF display of received frequency is possible.

LCD display contrast adjustment:

The contrast of the LCD can be changed via the front panel.

To change the contrast press and hold the YES/ENTER key, while holding down this key either press the UP arrow (to lighten the screen) or the down arrow (to darken the screen).

Menu structure overview:

All facilities are accessed from the front panel, via the menu system. The remote control can interrogate the unit whilst the menu is in use.

The keyboard consists of 16 keys. The block of 4 arrowed keys are used for jumping to associated menus and moving along character strings.

The YES/ENTER is the general confirmation button and the NO/CANCEL is the general abort/step back button.

The 0 to 9 keys are used to set values or to select a menu option. Only one push of the number button is required to select an item

You can change the contrast on the screen by holding in the YES button and pressing arrow UP or arrow DOWN

A short audible beep designates a valid key and a short buzz an invalid key.

The following table gives the indented menu structure and the related section title within this document;

3.1 Home Menu

3.1.1 Operating displays

3.1.1.1 UPC display

3.1.1.2 Rx level display

3.1.1.2a Rx level display – Internal beacon receiver

3.1.1.2b Rx level display – External beacon receiver

3.1.1.3 Video display

3.1.2 Status

3.1.3 Configure

3.1.3.1 UPC configure

3.1.3.1.1 Channels

3.1.3.1.1.1 Operating mode

3.1.3.1.1.2 Attenuation

3.1.3.1.1.3 Offset

3.1.3.1.2 Calibration

3.1.3.1.2.1 Clear sky level

3.1.3.1.2.2 Clear sky offset

3.1.3.1.2.3 External channel

3.1.3.1.2.4 Fade limit

3.1.3.1.2.5 Fade limit hysteresis

3.1.3.1.3 Compensation

3.1.3.1.3.1 Operating mode

3.1.3.1.3.2 Attenuation (manual mode only)

3.1.3.1.3.3 Range

3.1.3.1.3.4 Ratio

3.1.3.1.3.5 Step size

3.1.3.1.3.6 Slew rate

3.1.3.1.3.7 Sample period

3.1.3.1.3.8 Hysteresis

3.1.3.1.4 Scintillation

3.1.3.1.5 Beacon Input

3.1.3.2a Tracking configure (Internal tracking only)

3.1.3.2a.1 Video

3.1.3.2a.1.1 Frequency

3.1.3.2a.1.2 Span

3.1.3.2a.1.3 Reference level

3.1.3.2a.1.4 BW resolution

3.1.3.2a.1.5 10dB pad

3.1.3.2a.2 Beacon

3.1.3.2a.2.1 Sweep rate

3.1.3.2a.2.2 Sweep width

3.1.3.2a.2.3 Log output dB/volt

3.1.3.2a.2.4 Log offset

3.1.3.2a.2.5 ASB

3.1.3.2a.3 Downconverter

3.1.3.2a.3.1 Frequency

3.1.3.2a.3.2 Gain

3.1.3.2a.3.3 SHF

3.1.3.2a.3.3.1 Set SHF lo

3.1.3.2a.3.3.1.1 User

3.1.3.2a.3.3.1.2 5.15 GHz

3.1.3.2a.3.3.1.3 6.30 GHz

3.1.3.2a.3.3.1.4 10.0 GHz

3.1.3.2a.3.3.2 SHF

3.1.3.2a.3.3.3 Spectrum invert

3.1.3.2a.3.4 10MHz

3.1.3.2a.3.5 DC feed

3.1.3.2a.3.6 Voltage

3.1.3.2a.3.7 Tone

3.1.3.2a.4 RF Input Path

3.1.3.2a.5 Composite I/P Attenuation

3.1.3.2a.6 DC Output Limits

3.1.3.2b External Beacon configure (external tracking only)

3.1.3.2b.1 Input Range

3.1.3.2b.2 Beacon Slope

3.1.3.2b.3 Offset

3.1.3.2b.4 Option 17SJ

3.1.3.3 EXP configure

3.1.3.3.1 Channels

3.1.3.4 Pilot configure (Pilot generator enabled units only)

3.1.3.4.1 Frequency

3.1.3.4.2 Power

3.1.3.4.3 Carrier

3.1.3.5 Remote control

3.1.3.5.1 Set Remote mode

3.1.3.5.2 Setup RS485

3.1.3.5.3 Setup RS232

3.1.3.5.4 Setup Ethernet

- 3.1.3.6 Redundancy
 - 3.1.3.6.1 Identifier
 - 3.1.3.6.2 Change Over
 - 3.1.3.6.3 Mode
 - 3.1.3.6.4 List Units In System

- 3.1.4 Log
 - View
 - Clear
 - View graphs

- 3.1.5 Service
 - Test
 - Monitor points
 - Fan
 - Time & date
 - Trim 10MHz ref.
 - Reset
 - Tracking Rx LUT

- 3.2 Setup
 - Modify Parameters

3.1 Home menu

```
                HOME
1: Operatins displays
2: Status
3: Confisure
4: Log
5: Service
```

Pic 3.1 HOME menu.

The HOME menu is the base menu from which to perform any function. The HOME menu displays items which are particular to the configuration being used.

Press the appropriate numerical key to select the required sub-menu.

There is also a 'hidden' SETUP menu that can be accessed by pressing key '9' from this menu.

3.1.1 Operating displays

<pre>OPERATING DISPLAYS 1: UPC Display 2: Rx Level Display 3: Video Display</pre>	<pre>OPERATING DISPLAYS 1: UPC Display 2: Rx Level Display Int 3: Rx Level Display Ext 4: Video Display</pre>
---	---

Pic 3.1.1 OPERATING DISPLAYS menu (both options).

The Operating displays screen gives you access to menu items that will be used for everyday use.

Press the appropriate numerical key to select the required sub-menu.

If the internal Beacon Receiver option is not fitted, then this screen will not have the Video Display menu option visible.

3.1.1.1 UPC Display

```
Automatic Mode
Clear Sky Level:  -80.3dB
Beacon Level:    -174.9dB
Attenuation:     9.5dB
```

Pic 3.1.1.1a UPC MAIN DISPLAY.

The UPC main display screen is designed to give an overview of the relative levels of the Beacon signal, actual internal attenuation value and variable gain point. It is the main display intended for use on a day to day basis.

The 'clear Sky' beacon level must be set by the user before use, this corresponds to the maximum attenuation level.

The Attenuation display gives the actual value of variable attenuation at any given time (the above display Pic. 3.1.1.1a shows a fixed attenuation of 9.5dB).

In the event of the loss of beacon signal, beacon level going above clear sky condition or minimum attenuation reached a summary fault message will appear on the main screen.

3.1.1.2 Rx Level Display Screens

3.1.1.2a Internal Beacon Receiver

The screen shows the Rx frequency and the level of the Beacon in dBm.

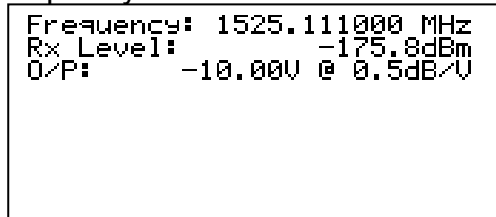

Pic 3.1.1.2.1 INTERNAL BEACON MAIN DISPLAY.

3.1.1.2b External Beacon Receiver

The screen shows the input Beacon voltage and its level in dB using the dB/V slope.

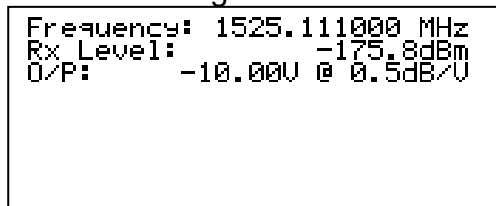

Pic 3.1.1.2.2 EXTERNAL BEACON MAIN DISPLAY.

3.1.1.3 Beacon Video Display Screen (only shown if internal Beacon Receiver is fitted)

This screen is specific for the Beacon Receiver portion of the unit (if fitted).

This screen displays the power of the frequencies inside the video frequency span (VS) where the video centre frequency (CF) is at half the video frequency span of the frequency span. RL is the Reference Level of the incoming signals in dBm.

The video centre frequency and video frequency span can be changed in the Video Display menu. To change the VS press the 'up arrow' to increase the frequency span and 'down arrow' key down to decrease it. The centre frequency can be changed with 1/10th of the current video frequency span. Increase the video centre frequency by pressing arrow key right and decrease it by pressing arrow key left.

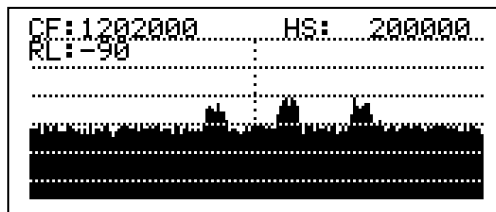

Pic 3.1.1.3 BEACON VIDEO DISPLAY.

3.1.2 Status screen

The Status screen shows the user settable parameters. The screen can be scrolled up and down using the arrows keys 'up' and 'down'.

```
----- UPC -----  
          Calibrated  
Mode:      Automatic  
Clear Sky Level: -80.3dB  
Beacon Level: -174.9dB  
Attenuation:  9.5dB  
----- COMPENSATION -----  
Range:      10.0dBv
```

Pic 3.1.2a UPC STATUS.

While viewing the status screen, the option to press the left or right arrow keys is available; this cycles through different status screens. These include:

- UPC – This includes the status of the internal channels
- Internal / External Tracking Receiver
- Unit
- External Channels
- EXP Unit – This covers the EXP unit (if attached), its PSUs and its channels

Either key will take you to the Unit status screen which is shown in the picture (Pic. 3.1.2b). The Unit status screen shows you software version, unit type, serial number, alarm summary and several other settings that affect the entire unit. To see the entire setup screen, scroll using the 'up' and 'down' arrow keys.

```
----- Unit -----  
          UPC7000 [2]  
Software Version:  1.13  
Serial No.:       0000  
Summary Alarm:    FAULT  
External Ref:     NOT Present  
----- Remote Control -----  
Local RS232 mode          v
```

Pic 3.1.2b UNIT STATUS SCREEN.

3.1.3 Configuration screen

The Configuration screen shows menu options which if selected allow the appropriate setting to be changed.

```
          CONFIGURE  
1: UPC Configure  
2: Tracking Configure  
3: Ext. Beacon Configure  
4: EXP Configure  
5: Pilot Configure  
6: Remote Control  
7: Redundancy
```

Pic 3.1.3a CONFIGURATION screen

3.1.3.1 UPC Configure

```
UPC CONFIGURATION
1: Channels
2: Calibration
3: Compensation
4: Scintillation
5: Beacon Selection
```

Pic 3.1.3.1a UPC CONFIGURATION screen

The UPC Configuration screen shows menu options for power control functions.

3.1.3.1.1 Channels

```
CHANNEL [1] CONFIGURATION
Use ↑/↓ to change channel
Mode: Manual
Atten:10.0dB Offset: 0.0dB

1: Operating Mode
2: Attenuation
3: Offset
```

Pic 3.1.3.1.1 Channel configuration

Channel configuration menu enables the operating mode of channels 1 to 16 to be modified.

Valid modes are; **'Off'** where the internal attenuator is switched out of circuit (switches to the by-pass condition).

'Manual'; where the internal compensating attenuator is switched in circuit. The user can adjust the internal (or external for use with other Peak UpLink products containing attenuators) variable attenuator manually via the front panel by pressing option 2 and using keypad or variable mode (or via remote control) to control the UpLink power. When selected from the 'Automatic' mode, the attenuation level initiates at the last value set during 'Automatic' mode operation. When selected from the 'Off-Line' mode, the attenuation level initiates at the Clear Sky (maximum attenuation) value.

'Automatic'; where the internal attenuator is switched in circuit. Internal (or external) compensating attenuator setting and hence UpLink power control is determined by the internal system automatically. (Pic. 3.1.3.1.1) shows channel 1 to be in the Automatic 'Auto' mode. The default setting is 'Off-line'.

When the channel is internal the user has the ability to trim the UpLink path Gain during the commissioning process by using the Offset menu option. This uses a portion of the variable attenuation range, so it is limited by the range of automatic compensation required (i.e. the internal variable attenuator has a 30dB range, so if 10dB range is selected for automatic compensation then a maximum fixed offset of 20dB is available). When the channel is external this offsetting is done via the attached unit.

To change the operating mode, use the arrow keys 'up' and 'down' to scroll to the desired setting. To accept the change press key "YES", press "NO" to cancel and return to previous menu screen.

For units with multi-channel compensation, use the arrow 'up' and 'down' to select the desired channel and then follow the above instructions to set the operating mode.

3.1.3.1.2 Calibration

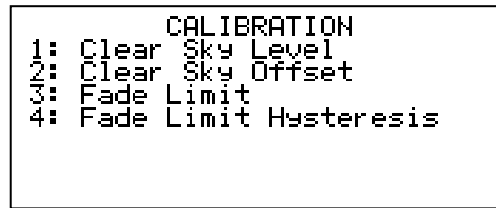

Pic 3.1.3.1.2 Calibration settings

The Calibration menu is critical to the correct functioning of the UPC unit. The 'calibrate clear sky' function allows the user to set the maximum attenuation reference value which is seen during clear sky conditions. The unit must be locked to a valid beacon and the unit must be under ideal clear sky conditions, when these parameters are met, access the Clear sky menu by pressing 1

3.1.3.1.2.1 Clear Sky Level

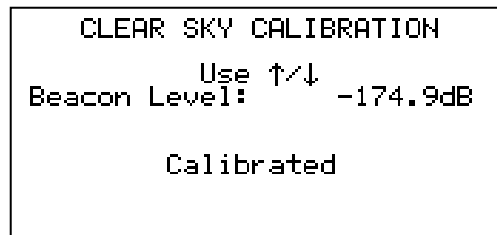

Pic 3.1.3.1.2.1 Calibration setting

When Clear sky conditions are met as above, pressing the 'up' or 'down' arrow to select calibrated and pressing yes will enter the detected power level setting into the saved clear sky value. By pressing yes the menu system will return instantly to the previous menu. To unset the calibrated clear sky value, press the 'up' or 'down' arrow to select not calibrated and press yes.

3.1.3.1.2.2 Clear Sky Offset

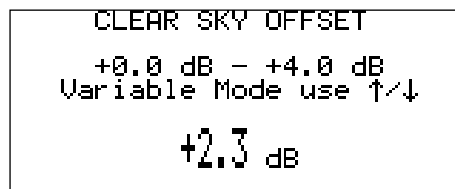

Pic 3.1.3.1.2.2 Clear Sky Offset

Clear sky offset allows the user to perform a calibration without clear sky conditions being met. The user can then add an offset to prevent the unit going into alarm when the received beacon level goes above the calibration point.

A Clear Sky Alarm fault (and resulting summary fault) will occur if the beacon goes above the Clear Sky Beacon Level + Offset (Correct Clear Sky Level), if configured in 1+1 redundancy, this will trigger switching which may be undesirable. It is possible to disable this fault by using the UPC MODIFY PARAMETERS menu, see section 3.2.

3.1.3.1.2.3 External Channel



Pic 3.1.3.1.2.3 External Channel

When the external channel calibration is set to calibrated, the UPC will remember what units are currently attached to it. If after calibration any of those units are removed, a “Missing External Channels” fault is generated. If this functionality is not required then do not calibrate the external channels. If no external channels are present, then this menu item is not shown.

3.1.3.1.2.4 Fade Limit

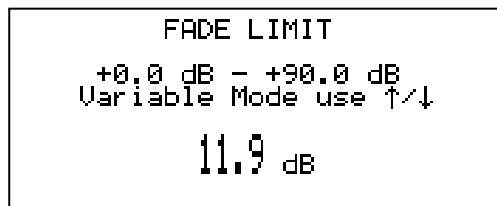

Pic 3.1.3.1.2.3 External Channel

The Fade Limit setting of the UPC allows a ‘Fade Limit Exceeded’ alarm to be generated when the Correct Clear Sky level exceeds the Fade Limit amount. This can be used by the user to pre-empt the UPC’s input value dropping too far. This alarm, if raised, does not stop the UPC from compensating signals. Alternative use is to use the software alarm to trigger a site diversity system changeover.

3.1.3.1.2.5 Fade Limit Hysteresis

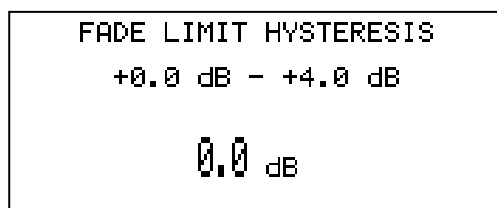

Pic 3.1.3.1.2.3 External Channel

When this is used in conjunction with the Fade Limit setting, will clear any ‘Fade Limit Exceeded’ after the Corrected Clear Sky level is \leq (Fade Limit – Fade Limit Hysteresis). This hysteresis stops the Fade Limit Exceeded alarm being raised and lowered in quick succession.

3.1.3.1.3 Compensation

The UPC Compensation screen shows user configurable settings for the power control functions

```
UPC COMPENSATION    1/2
1: Operating Mode
2: Attenuation
3: Range
4: Ratio
5: Step Size
6: Slew Rate
7: Sample Period
```

Pic 3.1.3.1.3a Compensation 1/2

This is page 1 of 2, the 2nd page allows the hysteresis setting to be accessed.

```
UPC COMPENSATION    2/2
1: Hysteresis
```

Pic 3.1.3.1.3b Compensation 2/2

3.1.3.1.3.1 Operating Mode

```
OPERATING MODE
Use ↑/↓ to change settings

Automatic
```

Pic 3.1.3.1.3 Compensation

There are three possible operating modes

Selection of the operating mode to automatic will allow the UPC function to operate all the connected attenuators according to the other UPC Compensation parameters. Using information of the tracking level from either the external beacon DC input or from the internal tracking receiver if this option is taken. Selection of the input data used is via the beacon selection menu in the UPC configuration menu 3.1.3.1.5

Selecting the mode to Manual will enable the previous screen with an attenuation menu which allows the user to manually control the attached attenuators.

Selecting the mode to Comparison, will allow both the internal tracking receiver level and the external beacon level to be used in a compensation calculation. One of the levels must come from a pilot signal that is transmitted through the uplink chain. Selection of which one is the pilot and which is the beacon is selected in 3.1.5.1.5

Here the pilot generated signal is not corrected and sent up to the satellite, its signal strength is measured on the downlink. Its path is subject to losses on both the uplink *and* the downlink paths.

We also measure a beacon signal strength, this is only subject to downlink losses. At clear sky calibration we set the following:

P_c = Measured pilot signal strength at calibration
 B_c = Measured beacon signal strength at calibration
 $C_o = P_c - B_c$ = Offset between calibrated signal strengths

When running:

P_n = Currently measured pilot signal strength

B_n = Currently measured beacon signal strength

Then the Δ we use for the working out of the attenuation, in the normal way is:

$$\Delta = (P_n - B_n) - (C_o)$$

3.1.3.1.3.2 Attenuation (manual mode only)

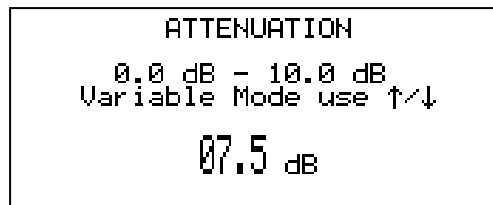

Pic 3.1.3.1.3.2 Attenuation

This allows the attenuation that would normally be evaluated based on the clear sky beacon level and the other compensation parameters, to be set via the user.

3.1.3.1.3.3 Range

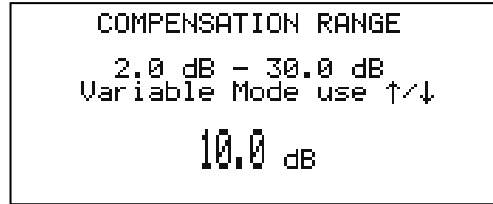

Pic 3.1.3.1.3.3 Range

The compensation range is the range of attenuation over which the variable attenuation will compensate for changes in Beacon level. All channels will be set to the same range and valid range values are from 2dB to 30dB & in this case the compensation range is shown as 10dB, see picture (Pic. 3.1.3.1.3.3). Pre-set ranges include 1dB, 2dB, 5dB, 10dB & 30dB or the user can enter a custom range value. The default setting is 10dB.

To change the pre-set compensation range values, use the arrow keys 'up' and 'down' (when in variable mode). Press key "YES" to accept change, key "NO" to cancel.

To select a custom range value, use the arrow keys 'left' or 'right' to get off the 'Variable mode' then the user can cycle through each character on the display to enter any value from 2 to 30dB. To accept the change in setting press key "YES", press "NO" to cancel and return to previous menu screen.

3.1.3.1.3.4 Ratio

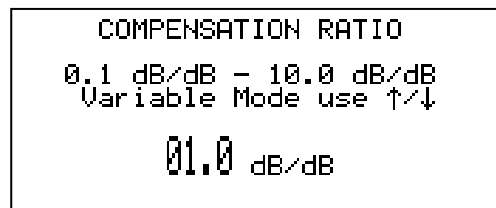

Pic 3.1.3.1.3.4 STEP SIZE adjustment

Ratio is applied directly to the compensation calculation and allows the user to make corrections for variations in uplink to downlink attenuation levels. This is user selectable from 0.1 to 10dB and for every 1dB drop in Beacon level, attenuation is reduced according to the above setting value. Setting resolution is to 0.1dB.

3.1.3.1.3.5 Step Size

The step size sets the variable attenuation increments for the compensation function. All channels will be set the same and valid pre-set step size values include 0.1dB, 0.2dB, 0.5dB, 1dB and 2dB & in this case the step size is shown as 1dB,

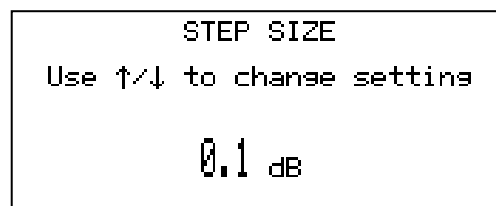

Pic 3.1.3.1.3.5 STEP SIZE adjustment

The default setting is 0.1dB.

To change the step size, use the arrow keys 'up' and 'down'. Press key "YES" to accept change, key "NO" to cancel.

3.1.3.1.3.6 Slew Rate

The slew rate sets the rate of change for the compensation function. All channels are set the same, with valid pre-set settings of maximum 1dB/10s (0.1dB/s), 1dB/20s, 1dB/50s & minimum 1dB/100s (0.01dB/s). In the table below the slew rate is shown as 1dB/20s (0.05dB/s), see picture (Pic. 3.1.3.1.3.6). This facility can be disabled and the current condition can be seen shown as 'on' (enabled) in the box to the right of the title. When disabled, the condition will be shown as "off" and the slew rate display will show '--dB/s'.

When [OFF] (disabled), the compensation attenuation value will be set immediately that a change is detected and calculated (after the sample period has elapsed).

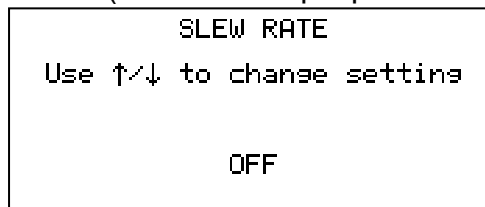

Pic 3.1.3.1.3.6 SLEW RATE adjustment

The default condition is [OFF]. When enabled, the default setting is '1dB/10s'.

To enable or disable toggle the condition by pressing key "1".

When "on" (enabled), to change the slew rate use the arrow keys 'up' and 'down'. Press key "YES" to accept change, key "NO" to cancel.

3.1.3.1.3.7 Sample Period

The sample period is the time over which the Beacon Receiver output signal is averaged before the attenuator compensation value is calculated and set. All channels are set the same and valid period values are from 0.2s to 10s & in this case the sample period is shown as 5s, see picture (Pic. 3.1.3.1.3.7). Pre-set ranges include 0.2s, 0.5s, 1s, 2s, 5s & 10s or the user can enter a custom value.

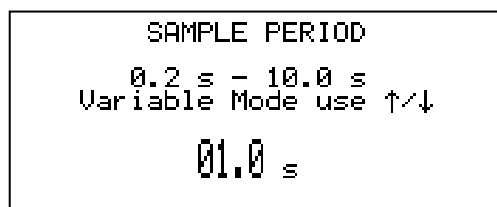

Pic 3.1.3.1.3.7 SAMPLE PERIOD

The default setting is '10s'.

To change the pre-set sample period values, use the arrow keys 'left' and 'right'. Press key "YES" to accept change, key "NO" to cancel.

To select a custom period, use the arrow keys 'up' and 'down' to increment or decrement in 0.1s steps. To accept the change in setting press key "YES", press "NO" to cancel and return to previous menu screen.

3.1.3.1.3.8 Hysteresis

This menu option allows the user to change the amount of hysteresis (from 0.0dB to 3.0dB) that is applied to the Beacon Level.

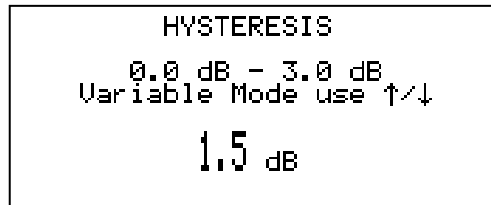

Pic 3.1.3.1.3.8 HYSTERESIS

This option allows the user to set an amount up to 3dB that the attenuation calculation will ignore before the attenuator will begin compensation on the uplink path. e.g. If the hysteresis is set to 1.5dB, then the difference between the clear sky dB level (clear sky calibrated level + clear sky offset) and the current beacon level will have to be greater than 1.5dB before any attenuation is removed.

3.1.3.1.4 Scintillation

This menu allows the user to enable or disable the scintillation configuration on the internal UPC channels.

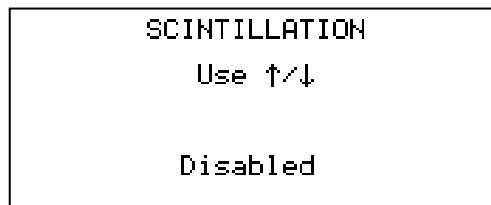

Pic 3.1.3.1.4 SCINTILLATION

This allows the attenuation of all internal channels to be updated every 5ms, rather than the normal 1s update period. It also overrides the front panel slew size to a non-standard value. A change in the calculated UPC attenuation is immediately performed, however every 0.1dB step in between the current and required attenuation point is set. This allows much smoother adjustment when following scintillation type fades.

3.1.3.1.5 Beacon Selection

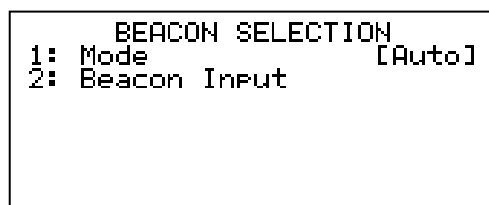

Pic 3.1.3.1.5 Beacon Selection

The is menu is only available when the internal tracking option is taken. Beacon Input, in UPC operating mode automatic, it allows the selection of the beacon data to be taken from either external beacon DC input, or the internal tracking receiver.

In comparison mode, it allows the choice of the pilot signal to be either the internal tracking receiver or the external beacon DC input.

If option 17d is fitted to the UPC then 'Mode' will also be available.

This allows the beacon input to be manually selected when in 'Manual' mode, or automatically selected when in 'Auto' mode. When in Automatic mode if the currently selected Beacon Input is in fault and the other input is OK then the beacon input is switched over. When option 17d is installed, there are two beacon inputs available, though only one can be used for the UPC operation at any one time. Which input is used can be chosen automatically, i.e. if one has a fault (read from the rear interface connector and the internal lock detection circuitry) then the other one is selected, assuming it is OK. Or the user can manually select which external beacon input to use. Each of the beacon inputs has its own range, slope and offset. Note that for smooth changeover between the two beacons they should both read similar dB levels for a given voltage input at clear sky calibration point.

3.1.3.2a Tracking Configuration screen (internal tracking only)

The Beacon Receiver tracking menu screen displays three submenu options, Video, Beacon, Downconverter, RF Input Path, Composite I/P Attenuation, & DC Output Limits, this menu is only applicable to units with internal tracking receivers.

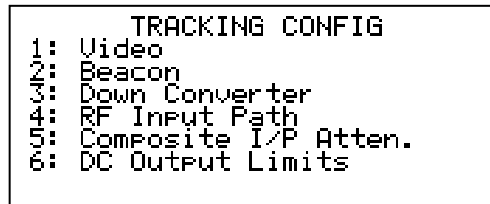

Pic 3.1.3.2a TRACKING CONFIGURATION

Pressing key “1” accesses the video configuration. The settings in the video configuration submenu changes settings for the video display screen. For more information about the video configuration see chapter 3.1.3.2a.1 Video Configuration.

Pressing key “2” accesses the beacon configuration menu. Here the configuration for the tracking beacon can be set. For more information about the beacon configuration go to chapter 3.1.3.2a.2 Beacon Configuration.

Pressing key “3” accesses the down converter configuration menu. Here the configuration for the tracking down converter can be set. For more information about the DownConverter configuration please see chapter 3.1.3.2a.3 DownConverter Configuration.

Pressing key “4” accesses the RF Input configuration menu. Here the configuration for the RF Input paths can be set. For more information about the RF Input Path configuration please see chapter 3.1.3.2a.4 RF Input Path Configuration.

Pressing key “5” accesses the Composite I/P Attenuator menu. Here the value of the Composite I/P attenuator can be set. For more information about the Composite I/P Attenuator please see chapter 3.1.3.2a.5 Composite I/P Attenuator.

Pressing key “6” accesses the DC Output limits configuration menu. Here the configuration for the tracking down converter can be set. For more information about the DownConverter configuration please see chapter 3.1.3.2a.6 DC Output Limits Configuration.

3.1.3.2a.1 Video Configuration

The Video Configuration screen shows 5 menu options. Option one to three will display other menu screens and allow for changing the setting. Chapters 3.1.3.2a.1 to 3.1.3.2a.5 will explain these.

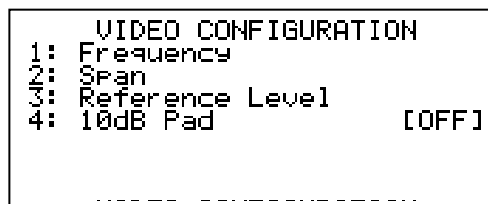

Pic 3.1.3.2a.1 VIDEO CONFIGURATION

Pressing key “4” toggles a 10dB attenuation pad on or off affecting the incoming signal to the video display screen.

3.1.3.2a.1.1 Frequency

The Video Centre Frequency can be changed in the menu screen, see picture (Pic. 3.1.3.2a.1.1) for an example of the menu screen. The two numbers on the third line in the display is the range the video centre frequency can be within. The maximum deviation from the Rx frequency is 25MHz. Changing the video frequency will affect the Video Frequency span.

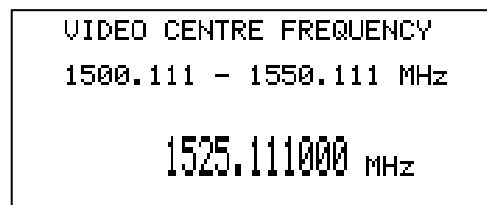

Pic 3.1.3.2a.1.1 FREQUENCY adjustment

The cursor is blinking over the number that is currently changeable. The number can be changed in several ways.

Pressing a number key “0” - “9” change the number to value of the key press and move the cursor to next position.

Pressing the arrow keys up and down increment or decrement the number the cursor is currently over. Pressing the arrows keys left and right changes the position of the cursor without changing the number it is on.

To make the change permanent the change has to be confirmed by pressing the “YES” key. Pressing key “NO” the change will be cancelled.

3.1.3.2a.1.2 Span

The Tracking Video Span is the frequency span shown on the video display screen chosen in the operation menu chapter 3.2.1. Picture (Pic. 3.1.3.2a.1.2) shows a Tracking Video Span menu screen.



3.1.3.2a.1.2 Pic TRACKING SPAN adjustmen

The video span is dependent upon the video centre frequency for its maximum limit. When it video centre frequency is equal the Rx frequency, the video has a maximum of 50 MHz centred on the Rx frequency, so ± 25 MHz. If the video centre frequency is changed in such a way that the video span frequency is too large, the video span will be changed accordingly to only display the new maximum frequency range. The video span frequency can be changed in the same way as the video centre frequency.

3.1.3.2a.1.3 Reference Level

The reference level menu screen in the video configuration menu is used to displace the signals on the video display menu. The Reference Level is the top line in the video display screen just above the RF value, see picture (Pic. 3.1.4.1.3a). The range is -80 dB to -100dB. To change the Reference level, use the arrow keys up and down, 5 dB per step.

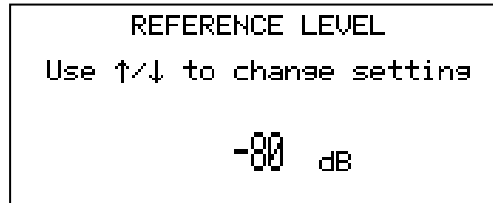

Pic 3.1.3.2.1.3 REFERENCE LEVEL

adjustment

Press “YES” to accept the change, “NO” to cancel.

3.1.3.2a.1.5 10dB Pad

Allows user to attenuate high-power signals to prevent compression of the video section.

3.1.3.2a.2 Beacon Configuration

The beacon configuration menu screen is the menu that is used to configure the beacon tracking. There are five menu options. The first four will take you to submenus the last choice, choice five ASB, toggles the ASB (Anti Side Band) on and off.

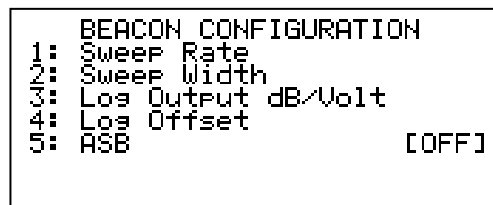

Pic 3.1.3.2a.2 BEACON CONFIGURATION menu

3.1.3.2a.2.1 Sweep Rate

The sweep rate is the frequencies the tracking system covers per second inside the frequency range set by the sweep width. In this case the sweep rate is 5 kHz/s, see picture (Pic. 3.1.3.2a.1).

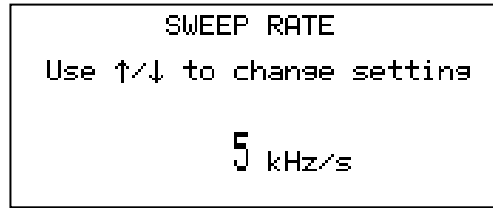

Pic 3.1.3.2a.1 SWEEP RATE adjustment

To change the sweep rate, use the arrow keys up and down. Press key “YES” to accept change, key “NO” to cancel.

3.1.3.2a.2.2 Sweep Width

The sweep width is the frequency range in which the beacon tracking system is looking for a tracking beacon. The sweep width centred on the Rx frequency being ± 20 kHz in this case, see picture (Pic. 3.1.3.2a.2.2), given a total frequency span of 40 kHz starting at the frequency $Rx_{frequency} - 20$ kHz.

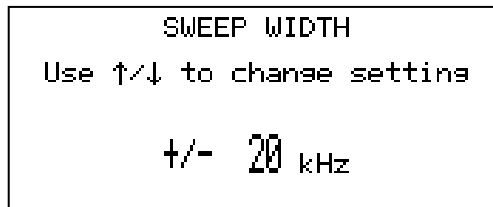

Pic 3.1.3.2a.2.2 SWEEP WIDTH adjustment

To change the sweep width, use the arrow keys up and down. Press key “YES” to accept the change, “NO” to cancel change.

3.1.3.2a.2.3 Log Output dB/Volt

The Log Output dB/Volt signal is dependent on the receive signal. Picture (Pic. 3.1.3.2a.2.3) shows the Log Output dB/Volt screen. Notice the line under the title is the actual output voltage.

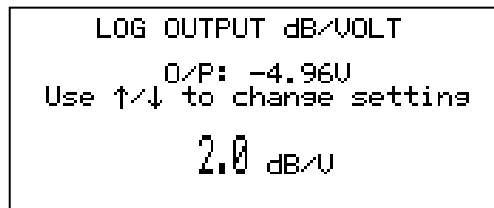

Pic 3.1.3.2a.2.3 LOG OUTPUT adjustment

To change the Output dB/Volt signal use the arrow keys up and down. Press key “YES” to accept change, “NO” to cancel.

3.1.3.2a.2.4 Log Offset

The Log Offset makes it possible to offset the voltage output. Picture (Pic. 3.1.3.2a.2.4) shows the Log Offset screen. Notice the line under the title is the actual output voltage.

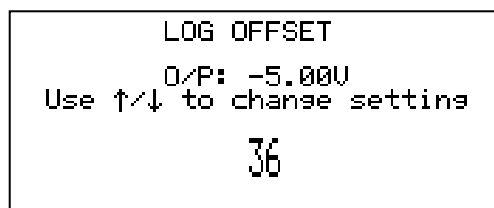

Pic 3.1.3.2a.2.4 LOG OFFSET adjustment

To change the Log Offset voltage, use the arrow keys up and down. Press key “YES” to accept change, “NO” to cancel.

3.1.3.2a.2.5 ASB

Allows user to turn on or off the anti-sideband locking function, which prevents the unit from locking to sidebands with power of up to 3dB down from main carrier, the unit will sweep around the locked signal and monitor this bandwidth for such sidebands, if the unit is locked to a sideband the unit will take itself out of lock and continue its original sweep until the unit is locked to the highest CW in band. When 3 full sweeps have been achieved the unit ASB function will automatically disable until loss of lock.

3.1.3.2a.3 Down Converter Configuration

The Down Converter Configuration screen displays 5 options, see picture. Options 1 to 3 are submenus of their own.

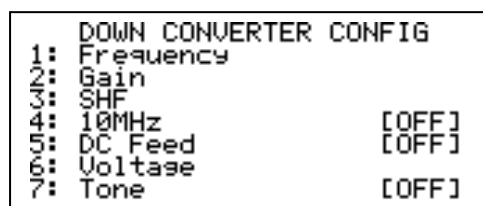

Pic 3.1.3.2a.3 DOWNCONVERTER CONFIGURATION menu

To change the Rx frequency press key “1”. A new menu screen will be displayed where it is possible to change the frequency. This frequency is the frequency the tracking part will try to find a beacon around.

Key press “2” will enter a new menu screen where changing of the signal gain is possible.

To enter the SHF menu press key “3”.

By pressing key “4” it is possible to toggle the 10 MHz on and off.

Pressing key “5” toggles the DC Feed on and off.

The 10MHz and DC are sent up the L-Band connection to lock and power the outside block converter. Note that it may take a few minutes after switching on power and Reference for the outside unit to stabilise and the alarm to clear.

3.1.3.2a.3.1 Beacon DownConverter Frequency

The Rx Frequency menu screen enables the user to change the receive frequency.

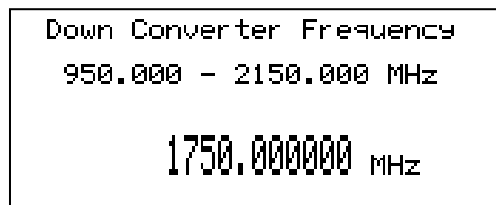

Pic 3.1.3.2a.3.1 DOWNCONVERTER FREQUENCY adjustment

Just below the screen title is the frequency range frequency can be set within.

A cursor should be flashing over the first cipher of the large numbers that shows the frequency at the bottom. Pressing any of the number keys “0” to “9” will set the cipher the cursor is over to that number and move the cursor to the next number. It is possible to increment and decrement the number using the arrow keys up and down. The cursor can be moved left and right by using the arrow keys left or right. If the frequency is out of range the display will display an “!!!!!! Out of Range !!!!!!” message.

To store a selected frequency that is in range use key “YES”. Key press “NO” will cancel and move the screen to previous menu.

3.1.3.2a.3.2 Beacon DownConverter Gain

Picture shows the Rx gain menu screen.

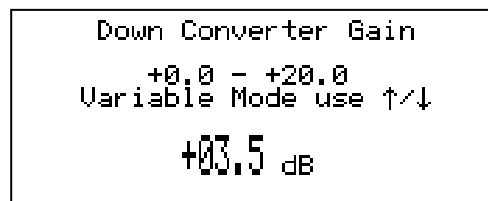

Pic 3.1.3.2a.3.2 DOWNCONVERTER GAIN adjustment

The range for the gain is from 0 to 30 dB as show on the line just below the screen title.

To change the gain, use the arrow keys up and down to increment or decrement that actual gain. To accept the change in gain press key "YES", press "NO" to cancel and return to previous menu screen.

3.1.3.2a.3.3 Beacon SHF Frequency Display

SHF stands for SUPER HIGH FREQUENCY and in this context, refers the SHF stage which precedes this L-Band unit.

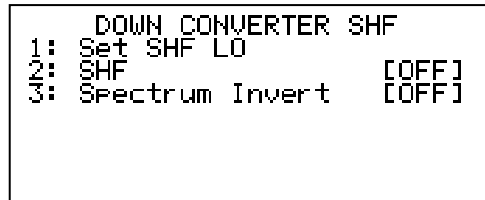

Pic 3.1.3.2a.3.3 SHF FREQUENCY display adjustment

This information is used to adjust for differences in 'rain fade' attenuation at the different frequencies, compared to the UpLink frequency (if also provided) it also is a convenient way to mathematically add the frequency effect of the external LNB or block converter on the downlink chain and display the actual Beacon Frequency.

For a block down converter or an LNB the local oscillator should be determined. This is the number which is added in this menu. To apply this value the SHF has to be switched ON

With Peak Communications equipment the following Local Oscillators apply;

PBD725	X Band DownConverter	6.30GHz
PBD420	C-Band DownConverter	5.15GHz (inverts spectrum)
PBD1095	Ku Band DownConverter	10.0GHz
PBD1170	Ku Band DownConverter	10.75GHz
PBD1225	Ku Band DownConverter	11.30GHz

Use of this feature allows the user to manipulate the unit to show the overall SYSTEM frequency. This is achieved by selecting both the Local Oscillator frequencies of the external SHF Block DownConverter. The SHF LO frequency and Gain/Loss are added/subtracted to the L Band output frequency (not if SHF is OFF) and power to obtain the SYSTEM output frequency and power level.

Example: If a UPC7000 series unit is connected to a PBD725 the UPC7000 display can be set to show the actual output frequency at Ku Band. The Block converter calculation in this case is simply the addition of the BDC Local Oscillator value to the L-Band frequency. If the input is set to 1200MHz (1.2GHz) and the LO is 6.30GHz the output is $1.2 + 6.3 = 7.50\text{GHz}$. IF the 6.30 value is entered as an SHF LO and the feature switched on with SHF ON/OFF you will see that any frequency shown on the unit is at X Band which also means you would have to input any new frequency at X Band.

3.1.3.2a.3.4 10MHz

Enables user to send reference frequency to an attached LNB or BDC via the centre pin of RF In

3.1.3.2a.3.5 DC Feed

Enables user to send reference DC voltage to an attached LNB or BDC via the centre pin of RF In

3.1.3.2a.3.6 Voltage

Enables user to set the value of the reference output voltage of the DC Feed, when the DC Feed is turned on.

3.1.3.2a.3.7 Tone

Enables user to send a reference 22kHz tone to an attached LNB or BDC via the centre pin of RF In.

3.1.3.2a.4 RF Input Path Configuration optional

The RF Input Path Configuration screen allows the user to select which RF path the converter is currently using, as well as the settings for this and the alternative RF path. If the UPC does not have the dual RF path option fitted then only one path's setting can be changed.

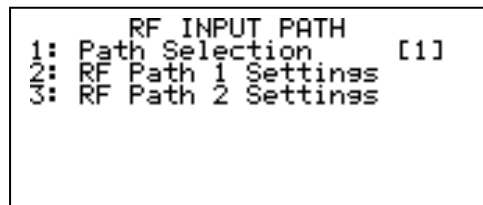

Pic 3.1.3.2a.4 RF INPUT PATH CONFIGURATION menu

To change the RF Path selection press key "1". This cycles through the two available RF Paths.

Keys "2" and "3" allow the user the change various settings for the RF Paths. See section 3.1.3.2a.3 for the various settings, and their usage. Not all the downconverter's settings are available through this menu, just the main ones.

3.1.3.2a.5 Composite I/P Attenuation

The Composite I/P Attenuation screen allows the user to modify the composite L-Band input attenuator in the UPC unit.

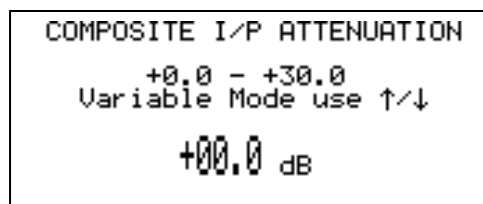

Pic 3.1.3.2a.5 COMPOSITE I/P ATTENUATION menu

To increase the dynamic range and prevent compression of the tracking downconverter, this menu allows the user to change the value of the input attenuator positioned after the internal L-Band input filter.

3.1.3.2a.6 DC Output Limits

The DC Output Limits menu screen allows the select then modify either the low output level limit or the high output level limit.

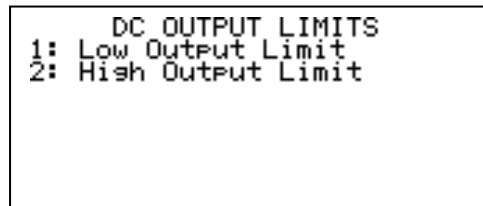

Pic 3.1.3.2a.6 DC OUTPUT LIMITS menu

If the internal tracking board DC output is used with an ACU that can only accept voltages within certain limits, this menu allows the user to set high and low limits of this DC voltage.

3.1.3.2b External Beacon Configuration screen

The External Beacon Configuration menu screen displays two submenu options, Input Range, Beacon Slope & Offset.

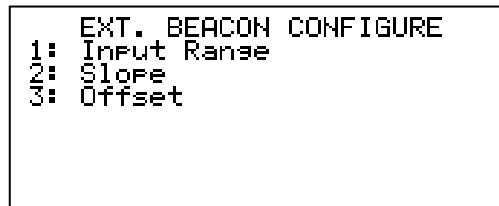

Pic 3.1.3.2b Ext. Beacon Configure

3.1.3.2b.1 External Input Range

This menu sets the allowable voltage input range for the external beacon input, picture (Pic. 3.1.3.2b.1) shows the input range screen.

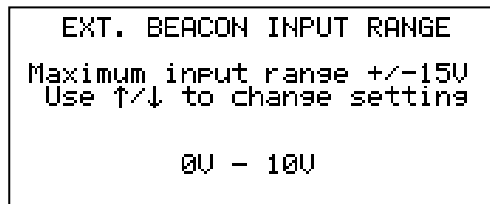

Pic 3.1.3.2b.1 INPUT RANGE display adjustment

To change the range, use the arrow keys up and down. Press key “YES” to accept change, “NO” to cancel. A fault is raised if the input is outside the range selected

3.1.3.2b.2 External Beacon Slope

The Beacon input signal is dependent on the voltage input. Picture (Pic. 3.1.4.2.2b) shows the beacon slope screen. Notice the line under the title is the actual input voltage.

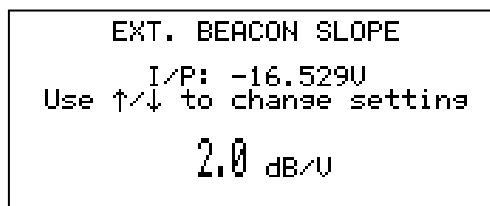

Pic 3.1.3.2b.2 SLOPE display adjustment

To change the beacon slope, use the arrow keys up and down. Press key “YES” to accept change, “NO” to cancel.

3.1.3.2b.3 External Beacon Offset

The Beacon input signal is dependent on the voltage input and slope, it is likely that this scaling combination will not give a correct dB reading. Therefore, this offset menu can be used to give an offset so that the dB level shown on screen is correct. Picture (Pic. 3.1.4.2.3b) shows the beacon offset screen.

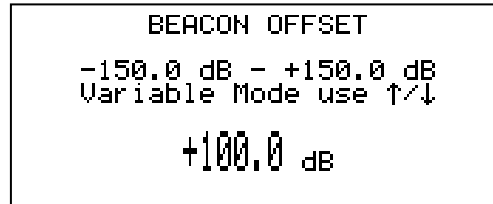

Pic 3.1.3.2b.3 OFFSET display adjustment

When in 'variable mode', as seen in the screen above the beacon offset can be changed by using the arrow keys up and down. To enter a value directly, move out of 'variable mode' by using the left/right keys. Then the value can be entered directly using the numeric keypad. Press key "YES" to accept change, "NO" to cancel.

3.1.3.2b.4 Option 17SJ

When option 17SJ is installed there are two external beacon inputs available, though only one can be used for the UPC operation at any one time. Which input is used can be chosen automatically, ie if one has an external fault (read from the rear interface connector) then the other one is selected, assuming it is OK. Or the user can manually select which external beacon input to use. Each of the external beacon inputs has its own range, slope and offset. Note that for smooth changeover between the two beacons they should both read similar dB levels for a given Voltage input. Option 17SJ changes the Pic 3.1.3.2b screen to:

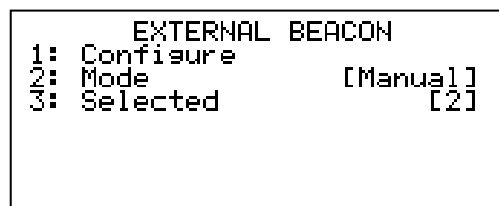

Pic 3.1.3.2b.4 Ext. Beacon (Option 17SJ)

Where a key press of 1 will take the user to a similar screen to Pic 3.1.3.2b, but it allows the user to cycle between the external beacon inputs by using the left and right arrow keys.

Key 2 cycles between 'Manual' and 'Automatic' mode for external beacon selection. Key 3 cycles between which external beacon input is currently being used, this works in Manual mode as well as Automatic mode.

3.1.3.3 EXP Configure

The EXP Configure screen shows user configurable settings for the EXP unit, if there is one attached

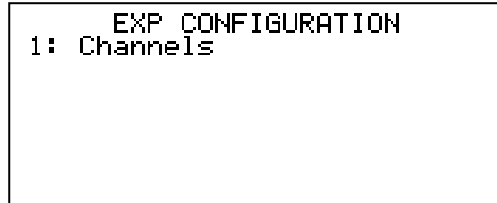

Pic 3.1.3.3 EXP Configuration

3.1.3.3.1 Channels

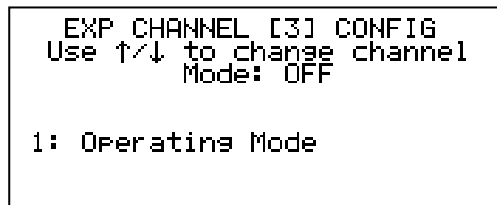

Pic 3.1.3.3.1 Channels

Channel configuration menu enables the operating mode of the EXP channels 1 to 10 to be modified.

Using the arrow 'up' and 'down' keys allows the user to select the desired channel and then follow the instructions below to set the operating mode. Only channels that are plugged into the EXP unit are configurable.

Valid modes are; '**Off**' where the internal attenuator is switched out of circuit.

'Manual'; where the internal compensating attenuator is switched in circuit. The user can adjust the variable attenuator manually via the front panel by pressing option 2 and using keypad or variable mode (or via remote control) to control the UpLink power. When selected from the 'Automatic' mode, the attenuation level initiates at the last value set during 'Automatic' mode operation. When selected from the 'Off' mode, the attenuation level initiates at the Clear Sky (maximum attenuation) value.

'Automatic'; where the internal attenuator is switched in circuit. Internal (or external) compensating attenuator setting and hence UpLink power control is determined by the internal system automatically. (Pic. 3.1.3.3.1) shows channel 3 to be in the 'Off' mode.

The user has the ability to trim the UpLink path Gain during the commissioning process by using the Offset menu option. This uses a portion of the variable attenuation range, so it is limited by the range of automatic compensation required (i.e. the internal variable attenuator has a 30dB range, so if 10dB range is selected for automatic compensation then a maximum fixed offset of 30dB is available).

To change the operating mode, use the arrow keys 'up' and 'down' to scroll to the desired setting. To accept the change press key "YES", press "NO" to cancel and return to previous menu screen.

3.1.3.4 Pilot Configure

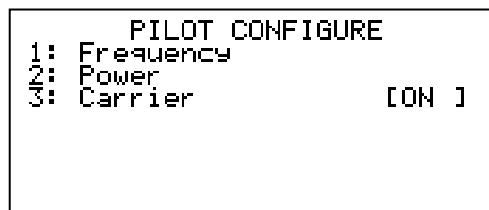

Pic 3.1.3.4.1 PILOT CONFIGURATION screen

The Pilot Configuration screen shows menu options for the pilot generator option, if this is enabled in the unit.

3.1.3.4.1 Frequency

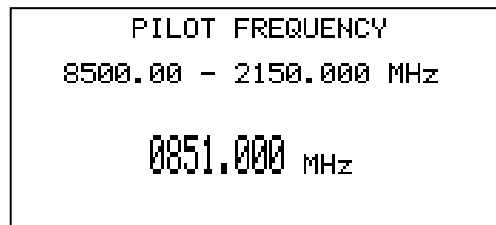

Pic 3.1.3.4.1 Pilot frequency configuration

The pilot frequency configuration menu allows the setting of the pilot frequency, see spec. for limits and step size.

3.1.3.4.2 Power

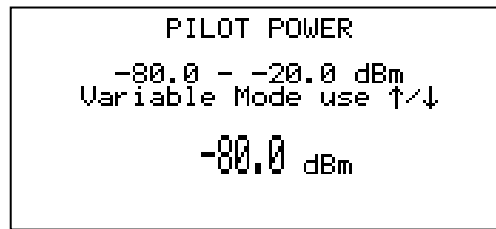

FIG 3.1.3.4.1 Pilot frequency configuration

The pilot power configuration menu allows the setting of the pilot power level, see spec for limits and step size.

3.1.3.4.3 Carrier

Pressing the '3' key will toggle the pilot carrier ON / OFF.

3.1.3.5 Remote Control

This screen provides access to all setup parameters for the remote interface.

```
RS485 (LOCAL Mode)
  Address:23
  Baudrate:19200

1: Set REMOTE mode
2: Setup RS485
3: Setup RS232
4: Set Protocol      [P7xxx]
```

Pic 3.1.3.5 RS485 setup

3.1.3.5.1 Set remote mode

Pressing 1 will toggle the unit into either local or remote mode.

```
CONFIGURE
1: Remote Control

Unit in REMOTE mode
no Configuration available
Change to LOCAL mode for
Configuration changes
```

Pic 3.1.3.5.1.1 CONFIGURE remote control

Note: In remote mode if you try to access the configuration menu while in remote the screen shown below will be displayed.

3.1.3.5.2 Setup RS485

The RS485 bus address can be set by entering in the number using the numeric keypad. After entering the unit address, the baud rate to be used is selected.

3.1.3.5.3 Setup RS232

The procedure for setting up the RS232 is the same as shown above for the RS485.

3.1.3.5.4 Set Protocol

The UPC7000 Series of converters only currently supports the P7xxx protocol specified in this manual.

3.1.3.5.5 Ethernet (Optional)

If the unit has been fitted with the Ethernet option, the remote-control menus are modified as follows:

```
REMOTE CONTROL
Ethernet (LOCAL Mode)
Address:N/A Baudrate:19200
Confis Port: RS485

1: Set REMOTE mode
2: Set Communications
3: Set Protocol      [P7xxx]
```

Pic 3.1.3.5.5a REMOTE CONTROL configuration screen in with Ethernet option

To set communications between RS232, RS485 or Ethernet, option 2 must be selected (Pic. 3.1.3.5.5a).

```
COMMUNICATIONS
1: Setup RS485
2: Setup RS232
3: Setup Ethernet
```

Pic 3.1.3.5.5b COMMUNICATIONS screen

The Setup RS485 and Setup RS232 menu options are the same as described previously. Set Ethernet menu option allows the Ethernet port to be used rather than the RS232/RS485 for remote control.

The menu choices (1-4) shown in Pic 3.1.3.5.5c allow the user to change the relevant Ethernet settings of the unit.

```
ETHERNET OPTIONS 1/2
1: DHCP [Enabled]
2: IPV4 Address
3: Subnet Mask
4: Gateway
5: TCP Port
6: TCP Socket Timeout
7: SNMP [Disabled]
```

Pic 3.1.3.5.5c Ethernet Options screen 1 of 2.

5 TCP Port – Sets the TCP port number used that allows serial communications messages to be sent, via TCP, to the unit.

6 TCP Socket Timeout – Sets the TCP socket timeout, i.e. the amount of time waited for with no communications before the TCP socket is automatically closed.

7 SNMP – Allows the SNMP protocol to be turned Disabled/Enabled.

```
ETHERNET OPTIONS 2/2
1: SNMP Trap Address
2: Set Options
```

Pic 3.1.3.5.5d Ethernet Options screen 2 of 2.

1 SNMP Trap Address – Sets the IP address of the device that will receive any SNMP trap error messages from the unit.

2 Set Options - Is used to set the Ethernet data all at once on the device, this must be used when trying to change the Ethernet settings.

See section 5.2 for more Ethernet information.

3.1.3.6 Redundancy

This screen provides access to all setup parameters for the redundancy.

```
1:1 REDUNDANCY
1: Identifier [A]
2: Change Over [N/A]
3: Mode [AUTO]
4: List Units In System
```

Pic 3.1.3.6.1 Redundancy configuration

3.1.3.6.1 Identifier

The identifier for each unit can be either [A] or [B], care should be taken that the units in a system don't have the same Identifier.

3.1.3.6.2 Change Over

This allows the OFFLINE unit to be moved into the ONLINE position.

3.1.3.6.3 List Units in System

This displays a menu screen showing the other units that can be seen on the same system as this unit. This screen only shows the UPCs it will not show any other external units that are being controlled by the UPCs.

3.1.4 Log

The log menu contains three submenus; View, Clear and View graphs, see picture (Pic. 3.1.4a).

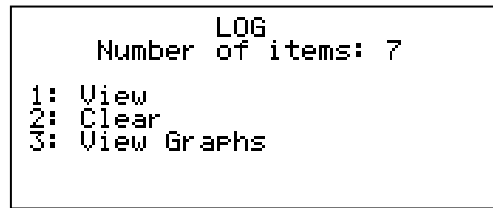

Pic 3.1.4a LOG MENU

Press key “1” on the key pad to view the event log that shows any errors, alarms or events that have happened to the unit. Picture (Pic. 3.1.6.3b) shows the view menu screen. It is possible to page through the log items but pressing the arrow keys ‘up’ and ‘down’.

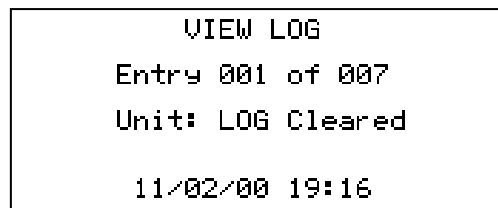

Pic 3.1.4b VIEW LOG

To clear the log, press key “2”. A confirmation menu screen will appear. Press key “YES” to clear the log or “NO” to cancel.

The View Graphs submenu, key press “3”, shows statistics of the unit.

3.1.5 Service

This menu is for maintenance personnel only and allows setting of the date and time, LOs inside the unit can be manually changed, fans switched on and off and the 10MHz internal reference frequency can be trimmed. This menu is factory set and it is not recommended that the user changes parameters within this menu without first consulting the factory.

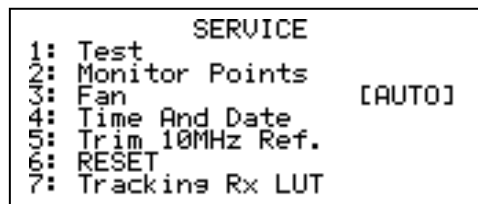

Pic 3.1.5 SERVICE menu

3.1.5.1 Fan

The UPC7000 series of converters are fitted with two fans. One fan operates all the time the prime power is applied the second fan can be set to [ON] [OFF] or [AUTO]. In auto mode the fan will operate when the unit internal temperature rises above the set point.

3.1.5.2 Tracking Rx LUT

This facility allows the entry of a Look Up Table (LUT) that gives absolute power calibration across the receiver frequency range for use with 1+1 redundancy systems. The LUT helps to match the absolute received level, when two units are used in a system. In use, it can reduce switch over level changes of the uplink compensation paths to within 0.1dB when correctly setup.

If UPC units are ordered in a redundancy configuration then Peak Communications will test all parts as a 'system' to produce a full look up table for both UPC units. These LUT values are stored in the UPC unit and are also recorded in the test results, if the unit is reinitialised for any reason the original values should be re-entered.

Peak Communications create a full LUT covering the whole receive frequency range, allowing for any beacon frequency during use.

If a UPC fails and requires replacement or a 2nd UPC and P1000 is added to create a new 1+1 system, then it ideally it needs to be fully tested with the existing online unit to produce a new LUT table, which is quite a time-consuming test that requires a signal generator to simulate the beacon signal across the receiver frequency range.

Alternatively, where the beacon frequency is known, an abridged procedure can be adopted to calibrate at the single frequency:

Note; use these instructions when replacing a unit in an existing redundancy system (one unit will already have correct LUT data entered).

- Connect the full system together with all associated cabling.
- Using the factory settings menu entered by pressing both '0' & '9' keys when in the home screen, go to <modify parameters> then select <UPC>, <redundancy compensation> menu, in this instance one unit will have been corrected for the P1000 unit loss and will have a value shown (nominally 10dB), enter this value into the newly introduced UPC unit. Press 'Yes' key to save value then exit the menu (repeat presses of the 'No' key will take you back to the main menu).
- Select the correct beacon frequency on both units and allow the internal beacon receivers to lock. The existing unit will read the correct absolute received power present at the input of the P1000 unit. The newly introduced UPC unit should now read a similar value, it is now necessary to manipulate the Look Up Table (LUT) on this unit to produce absolute front panel reading exactly the same as the existing unit.
- Record the received level of the unit with the full LUT and note the L-Band frequency
- Record the received level of the unit to be adjusted, the calculated compensation value will be the inverse of the difference between both units.
- By using the service menu on the unit with no LUT entered, select the closest frequency below the required L-Band frequency and input the calculated compensation value, go the LUT frequency closest above the required L-Band beacon frequency and input the same calculated compensation value, now exit the menu and monitor the absolute received power of the two units. They should

now read exactly the same absolute received power, if this is not realised then adjust the two LUT values empirically until the two units read the same.

When there is no LUT data in either unit (when upgrading from a single UPC to a redundant system), then a similar procedure is applicable, but initially both units will need to have a nominal beacon level compensation value entered. One unit is then chosen as the 'reference' and the other unit LUT values must be measured, calculated and inputted.

3.2 Setup

```
                SETUP
1: Initial Setup
2: Serial Number
3: Modify Parameters
4: 15dB Pad
5: Program Checksum
```

Pic 3.2 SETUP MENU

This menu is 'hidden' and is intended for maintenance personnel only. It allows setting of the unit type, serial number, modification of parameters & factory setup of the internal operation. This menu is factory set and it is not recommended that the user changes parameters within this menu without consulting the factory as permanent damage to the unit may occur.

The menus are accessible using '0' + '9' keys when in the home screen.

3.2.1 Modify Parameters

This menu and all sub-menus are factory set and it is not recommended that the user changes other parameters within this menu without consulting the factory as permanent damage to the unit may result!

From the SETUP menu, select the MODIFY PARAMETERS screen.

```
                MODIFY PARAMETERS
1: Tracking
2: UPC
3: Unit
```

Pic 3.2.1 MODIFY PARAMETERS MENU

From the MODIFY PARAMETERS screen, selecting any of the items will take you to a PARAMETERS screen that will list the available parameters, an example of which is shown below:

```
                PARAMETERS
Operating Display Timeout
                Demo Mode
                PSU 36V
Ignore CoaxSwitch
                Alarm Timeout
                Ethernet Option
```

Pic 3.2.2 PARAMETERS MENU

The tables below show a list of parameters and their uses, there are more available but they are not mentioned here as they have special uses and should not be changed without consultation with the factory.

Tracking Parameters:

Parameter	Description
Min Gain	Sets the minimum gain enterable
Max Gain	Sets the maximum gain enterable
Min Frequency	Sets the minimum frequency enterable
Max Frequency	Sets the maximum frequency enterable
Min Gain on Startup	Sets the gain to minimum on restart
Ignore External Alarm	Ignores the external alarm input pin
Ignore External Mute	Ignores the external mute input pin
DAC7216 DtoA Fitted	Selects the DAC type used on the PCB
Video Offset	Tracking receiver video offset
DC O/P Offset	Tracking receiver DC output offset

UPC Parameters:

Parameter	Description
Redundancy Compensation	Used with the Redundancy LUT, see section 3.1.5.2.
Disable Clear Sky Fault	Disables the Clear Sky Fault. So, if the beacon level goes above the Clear Sky Level, no fault is generated, and no summary alarm, so no redundancy switching is performed. See section 3.1.3.1.2.1.

Unit Parameters:

Parameter	Description
Operating Display Timeout	Not used anymore
Demo Mode	Puts the unit into demo mode, forces all the unit voltages and faults to OK.
PSU 36V	If ON, this says the unit has a 36V PSU, otherwise it is the now normal 27V
Ignore CoaxSwitch	Ignores the coax switches with regards to passive 1:1 redundancy.
Alarm Timeout	The timeout in seconds after which the alarms are read on start-up.
Ethernet Option	Selects the type of Ethernet board used in the unit, the choices are: Digi – new Ethernet with SNMP support Moxa – old Ethernet without SNMP support None – no Ethernet Default is OFF
Tracking Temp Compen	Turns the tracking receiver compensation on/off, the default is ON
Remote Version	This option allows the software to emulate the remote control of the software version selected here. See section 5.2.

4. REDUNDANCY

The UPC7000 series of automatic uplink power controllers interface with the Peak CANBUS® system for 1+1 redundancy.

4.1 1+1 Redundancy (switched)

For 1+1 switched redundant operation a pair of matching UPC7000 series units is required along with a P1000 series switch unit.

Description of P1000 Series units, P1002L (dual channel unit) shown in drawing below

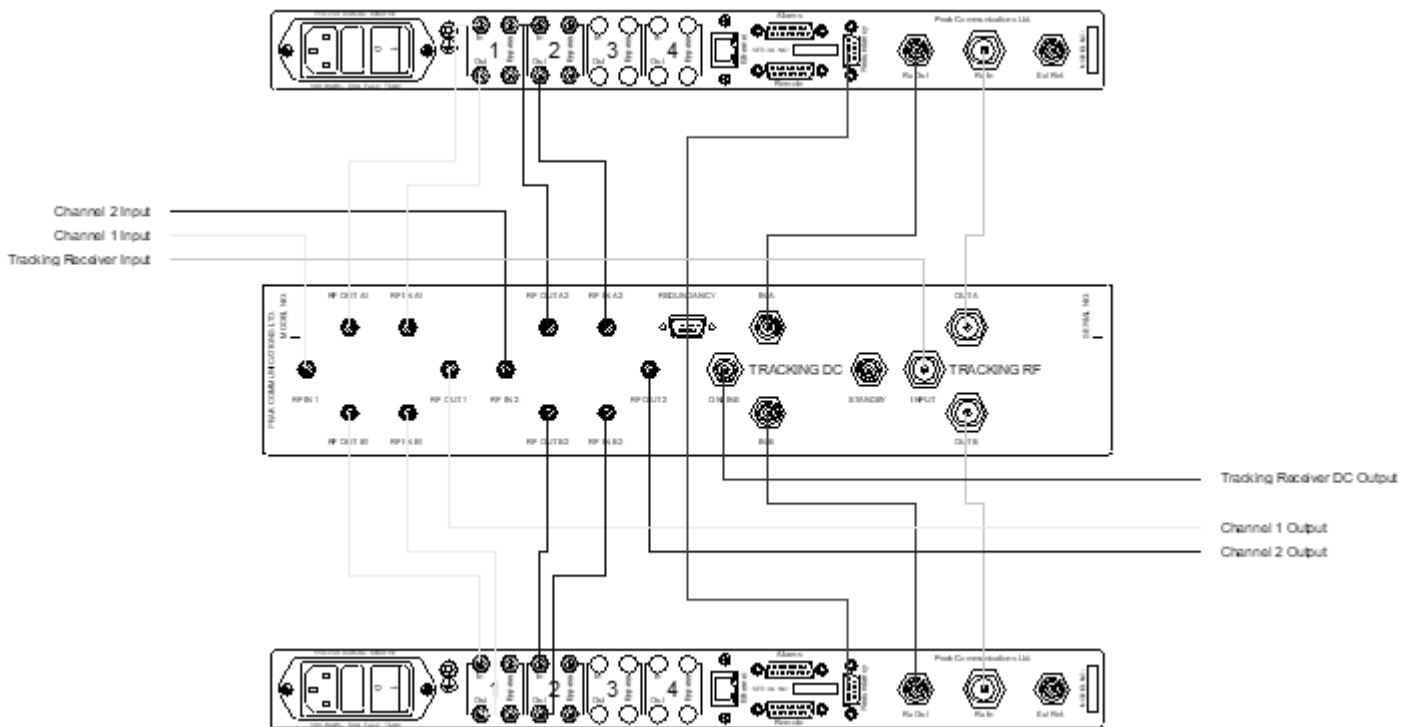

The tracking section utilises a DC and 10MHz pass, L-Band power splitter along with a 6dB DC pass RF attenuator to allow channel matching when a port is disconnected. RF power is therefore attenuated by 10dB between Tracking RF input and the two RF outputs.

There is a menu in the UPC units to negate this power loss from the front panel absolute received power reading, if this has not been added at the factory during test then it is located by the following selection

From home screen, press 0, 9. This enters a factory menu, select modify parameters, then select UPC and then select Beacon Level Compensation. Enter the value of 10dB in this instance.

10MHz power is attenuated by 4dB between Tracking RF input and the two RF outputs. DC attenuation is negligible and will pass 1Amp at 22V

In use the 10MHz is only selected from the online unit, DC is selected from both the online and offline converters. On switch over the loss of 10MHz during switchover time can result in LNB frequency loss and therefore tracking receiver loss, this must be

allowable in the UPC system if an externally referenced LNB is used. If this cannot be tolerated then a separate LNB driver unit must be used.

In use, one unit is set to identifier "A" and the other to identifier "B". The P1000 series unit is connected to the rear panel 9-way connector with the supplied cables and the units will self-detect and set one unit to online and the other will be set to standby. All parameters are constantly passed from the online unit to the offline unit; this requires any changes to be made to the configuration of both units to be made on only the online UPC unit. A changeover will be caused by an alarm detected in the online unit or changeover (keypad 2) being selected, this will result in the standby taking over the RF + DC path, making itself the online unit.

A manual changeover can be made by selecting the correct option from the standby unit, note that this option is only available on the offline unit.

The Tracking DC section is a DC rated transfer switch allowing online and offline monitoring of the individual tracking receiver DC received strength voltage, careful use of the DC output voltage offset menu must be used to match the voltages present during site installation, as this is one of the few parameters not to be transferred via the CANBUS® connector due to the analogue nature of the circuitry

The uplink path switch sections are configured as RF path switches to pass the signal through the online UPC variable attenuation sections, optionally they can be fitted with DC and 10MHz pass as per customer requests

Changeover time between a failed online unit and good offline unit is around 3s, during this time the RF path will fall-back to the UPC failsafe path if the option has been fitted. It is critical that the failsafe external path attenuation is carefully selected to function correctly in this instance.

Units ordered in a 1:1 configuration are set during final test to have minimal absolute RF detection level variation, this test is only performed as required, if the system must have a replacement UPC introduced then this variation test must be performed by request.

The offline unit in a redundancy system, as stated above, has its settings continually updated through the online unit, as such the configuration menus are not available, other than the Redundancy and Remote control. This is also true for the serial port and web interfaces.

5. REMOTE CONTROL

The unit is currently only capable of P7xxx remote control protocols

5.1 P7xxx Protocol

The unit transmits and receives data serially in an asynchronous format using the standard ASCII character set. The serial data consists of message frames composed of the following message characters: STX, BYTE COUNT, DEVICE ADDRESS, INSTRUCTION, BODY, CHECKSUM, ETX. All characters are compulsory except for the message body. The presence of a message body is determined by the message type (INSTRUCTION). The total number of message characters in a message frame may range from a minimum of 6 to a maximum of 255.

The remote control follows the following protocol: (in byte form)

[STX] start of message character #02

[B] char defining how many characters are in the message including the STX & ETX parts.

[A] **Address of unit.** Address ranges from ASCII character 001 to 255.

[I] **Instruction number**
See List below

[MESSAGE]

Numerous characters from length 0 upwards

[CHKSUM]

The checksum is used to verify the accuracy of the message frame. The checksum is defined as the summation of all the bytes in the message, **beginning** with the 3rd byte (DEVICE ADDRESS) and extending through the body of the message, **ending** with the last byte before the checksum. The total of the bytes is then ANDed with 255 so that the checksum is truncated to a single byte.

[ETX] End of transmission character #03

All message to and from the unit follow the above protocol with a character format of 8 data bits, one stop bit, no parity, baud rate 19200, 9600, 4800, 2400, 1200 or 300. Note; that all numeric values are shown as decimal.

Instruction Number List: (in decimal) :

To UPC7XXX unit	From UPC7XXX unit	Description
20		Requests Tracking receiver / UPC / UPC Channel / External beacon receiver / EXP / EXP Channel / Pilot generator status / Dual PSU status
	21	Responds with status
22		Requests setting changes
24		Set Remote/Local Mode request
30		Requests the number of unread alarm log entries
	31	Responds with number of unread alarm log entries
32		Requests alarm log entry
	33	Responds with alarm log
34		Requests alarm log clear
36		Requests next unread alarm log entry
	37	Responds with next unread alarm log entry
40		Asks for the main Unit settings
	41	Replies with the Unit Settings
45		Requests redundancy status
	46	Responds with redundancy status
47		Requests redundancy changes

Instruction 20 (Tracking receiver / UPC / External beacon receiver / EXP Status Request):

Message Byte No.	Set Value / (example)	Length (bytes)	Description
1	02	1	STX
2	?	1	No of bytes in message
3	?	1	Address
4	20	1	Message instruction
5	('K')	1	Device we are asking the information for: 'K' = Tracking Receiver 'E' = External Beacon Receiver 'U' = UPC 'u' = UPC extra information (option 17d only) 'P' = EXP Expansion Unit. 'C' = UPC Channel 'c' = EXP Channel 'i' = Pilot Generator 'A' = Composite Attenuation 'F' = RF Paths 'L' = DC Output Limits The Tracking Receiver & External Beacon Receiver are mutually exclusive, if you ask for the wrong one, whose option isn't fitted, you won't get a response.
6	?	1	Checksum
7	03	1	ETX

Instruction 20 (Channel Status Request):

Message Byte No.	Set Value / (example)	Length (bytes)	Description
1	02	1	STX
2	?	1	No of bytes in message
3	?	1	Address
4	20	1	Message instruction
5	('C')	1	'C' = Channel
6	('12')	2	Channel number we are asking the status of e.g. "12" - channel 12
8	?	1	Checksum
9	03	1	ETX

Instruction 20 (EXP Channel Status Request):

Message Byte No.	Set Value / (example)	Length (bytes)	Description
1	02	1	STX
2	?	1	No of bytes in message
3	?	1	Address
4	20	1	Message instruction
5	('c')	1	'c' = EXP Channel
6	('12')	2	Channel number we are asking the status of e.g. "10" - channel 10
8	?	1	Checksum
9	03	1	ETX

Instruction 20 (Pilot Generator Request):

Message Byte No.	Set Value / (example)	Length (bytes)	Description
1	02	1	STX
2	?	1	No of bytes in message
3	?	1	Address
4	20	1	Message instruction
5	('i')	1	'i' = Pilot Generator
6	?	1	Checksum
7	03	1	ETX

Instruction 20 (Dual PSU Request):

If the unit doesn't have the dual PSUs fitted this message is ignored.

Message Byte No.	Set Value / (example)	Length (bytes)	Description
1	02	1	STX
2	?	1	No of bytes in message
3	?	1	Address
4	20	1	Message instruction
5	('p')	1	'p' = PSUs
6	?	1	Checksum
7	03	1	ETX

Instruction 20 (Composite Input Attenuation):

Message Byte No.	Set Value / (example)	Length (bytes)	Description
1	02	1	STX
2	?	1	No of bytes in message
3	?	1	Address
4	20	1	Message instruction
5	('A')	1	'A' = Composite Input Attenuation
6	?	1	Checksum
7	03	1	ETX

Instruction 20 (RF Paths):

Message Byte No.	Set Value / (example)	Length (bytes)	Description
1	02	1	STX
2	?	1	No of bytes in message
3	?	1	Address
4	20	1	Message instruction
5	('F')	1	'F' = RF Paths
6	?	1	Checksum
7	03	1	ETX

Instruction 20 (DC Output Limits):

Message Byte No.	Set Value / (example)	Length (bytes)	Description
1	02	1	STX
2	?	1	No of bytes in message
3	?	1	Address
4	20	1	Message instruction
5	('L')	1	'L' = DC Output Limits
6	?	1	Checksum
7	03	1	ETX

Instruction 20 (External Beacon):

Message Byte No.	Set Value / (example)	Length (bytes)	Description
1	02	1	STX
2	?	1	No of bytes in message
3	?	1	Address
4	20	1	Message instruction

5	('E')	1	'E' = External beacon
6	?	1	Checksum
7	03	1	ETX

Instruction 20 (External Beacon Inputs (option 17SJ only)):

Message Byte No.	Set Value / (example)	Length (bytes)	Description
1	02	1	STX
2	?	1	No of bytes in message
3	?	1	Address
4	20	1	Message instruction
5	('e')	1	'e' = External beacon, extra information
6	('1')	1	'1' = External beacon input 1 '2' = External beacon input 2 '3' = External beacon global configuration
7	?	1	Checksum
8	03	1	ETX

Instruction 20 (UPC Extra Information (option 17d only)):

Message Byte No.	Set Value / (example)	Length (bytes)	Description
1	02	1	STX
2	?	1	No of bytes in message
3	?	1	Address
4	20	1	Message instruction
5	('e')	1	'u' = UPC extra information
6	?	1	Checksum
7	03	1	ETX

Instruction 21 (Internal Tracking Status Request Reply [L-Band Beacon Input]):

Message Byte No.	Set Value / (example)	Length (bytes)	Description
1	02	1	STX
2	?	1	No of bytes in message
3	?	1	Address
4	21	1	Message instruction
5	('K')	1	Device we are asking the information on: 'K' = Tracking
6	('01202000000' = 01.202000000 Ghz)	11	Video Centre Frequency in Hz
17	('20000000' = 20MHz)	8	Frequency Span in Hz Span max 25 MHz
25	('080' = -80dB)	4	Video Reference Level in dB
29	('1')	1	Band Width Resolution in kHz 1 = 1 kHz, 6 = 6 kHz
30	('1')	1	10 dB Pad ON/OFF '0' = OFF '1' = ON
31	('1')	1	Sweep Rate Index 0 – 7 0 = "2.5 kHz/s" 1 = "5 kHz/s", 2 = "10 kHz/s", 3 = "20 kHz/s", 4 = "40 kHz/s", 5 = "80 kHz/s" 6 = "120 kHz/s" 7 = "240 kHz/s"
32	('1')	1	Sweep Width Index 0 – 4 0 = "+/- 20 kHz" 1 = "+/- 50 kHz" 2 = "+/- 100 kHz" 3 = "+/- 200 kHz" 4 = "+/- 500 kHz"
33	('1')	1	Log dB/Volt Index 0 – 4 0 = 0.5 dB/Volt 1 = 1 dB/Volt 2 = 2 dB/Volt 3 = 5 dB/Volt 4 = 10 dB/Volt
34	('080')	3	Log Offset 000 – 100.
37	('0')	1	ASB ON/OFF '0' = OFF '1' = ON
38	('+0467')	5	DC Output. Divide by 100 to get the actual voltage.
43	('+0467')	5	Rx Level in 0.1dB steps
48	('10123456789' = 10.123456789 GHz)	11	Frequency in Hz The frequency of the unit.
59	('+0123' = 12.3 dB)	5	Gain in 0.1dB steps
64	('X')	1	Not used
65	('1')	1	10MHz ON/OFF '0' = OFF '1' = ON
66	('1')	1	DC Feed ON/OFF '0' = OFF '1' = ON
67	('01')	2	DC Feed Voltage '01' = 13.0V '02' = 13.3V '03' = 13.7V '04' = 14.0V '05' = 14.3V '06' = 14.7V '07' = 15.0V

			'08' = 18.0V '09' = 18.5V '10' = 18.8V '11' = 19.2V '12' = 19.5V '13' = 19.8V '14' = 20.0V '15' = 20.5V *new in version 2.00
69	('1')	1	22kHz Tone ON/OFF '0' = OFF '1' = ON *new in version 2.00
70	('1')	1	SHF LO ON/OFF '0' = OFF '1' = ON
71	('20123456789' = 20.123456789 GHz)	11	SHF Frequency in Hz
82	('1')	1	SHF Spectrum Invert ON/OFF '0' = OFF '1' = ON
83	('0')	1	Tracking Out of Lock '0' = OK '1' = FAULT
84	('0')	1	2ND LO Fault '0' = OK '1' = FAULT
85	('23/12/02 12:34:56')	17	OK Since time/date string, if there is a fault with this part of the unit then the string is blank.
102	?	1	Checksum
103	03	1	ETX

Instruction 21 (Internal Tracking Status Request Reply [Non L-Band Beacon Input]):

Message Byte No.	Set Value / (example)	Length (bytes)	Description
1	02	1	STX
2	?	1	No of bytes in message
3	?	1	Address
4	21	1	Message instruction
5	('K')	1	Device we are asking the information on: 'K' = Tracking
6	('01202000000' = 01.202000000 Ghz)	11	Video Centre Frequency in Hz
17	('20000000' = 20MHz)	8	Frequency Span in Hz Span max 25MHz
25	('080' = -80dB)	4	Video Reference Level in dB
29	('1')	1	Band Width Resolution in kHz 1 = 1 kHz, 6 = 6 kHz
30	('1')	1	10 dB Pad ON/OFF '0' = OFF '1' = ON
31	('1')	1	Sweep Rate Index 0 – 7 0 = "2.5 kHz/s" 1 = "5 kHz/s", 2 = "10 kHz/s", 3 = "20 kHz/s", 4 = "40 kHz/s", 5 = "80 kHz/s" 6 = "120 kHz/s" 7 = "240 kHz/s"
32	('1')	1	Sweep Width Index 0 – 4 0 = "+/- 20 kHz" 1 = "+/- 50 kHz" 2 = "+/- 100 kHz" 3 = "+/- 200 kHz" 4 = "+/- 500 kHz"
33	('1')	1	Log dB/Volt Index 0 – 4 0 = 0.5 dB/Volt 1 = 1 dB/Volt 2 = 2 dB/Volt 3 = 5 dB/Volt 4 = 10 dB/Volt
34	('080')	3	Log Offset 000 – 100.
37	('0')	1	ASB ON/OFF '0' = OFF '1' = ON
38	('+0467')	5	DC Output. Divide by 100 to get the actual voltage.
43	('+0467')	5	Rx Level in 0.1dB steps
48	('10123456789' = 10.123456789 GHz)	11	Frequency in Hz The frequency of the unit.
59	('+0123' = 12.3 dB)	5	Gain in 0.1dB steps
64	('X')	1	Not used
65	('X')	1	Not used
66	('X')	1	Not used
67	('X')	2	Not used *new in version 2.00
69	('X')	1	Not used *new in version 2.00
70	('X')	1	Not used
71	('XXXXXXXXXXXX')	11	Not used
82	('X')	1	Not used
83	('0')	1	Tracking Out of Lock '0' = OK '1' = FAULT
84	('0')	1	2ND LO Fault '0' = OK '1' = FAULT

85	('0')	1	SHF Fault '0' = OK '1' = FAULT Note this byte is only in the message if the unit has been fitted with options 2a-2e.
86	('23/12/02 12:34:56')	17	OK Since time/date string, if there is a fault with this part of the unit then the string is blank.
103	?	1	Checksum
104	03	1	ETX

Instruction 21 (UPC Status Request Reply):

Message Byte No.	Set Value / (example)	Length (bytes)	Description
1	02	1	STX
2	?	1	No of bytes in message
3	?	1	Address
4	21	1	Message instruction
5	('U')	1	Device we are asking the information on: 'U' = UPC
6	('0')	1	Clear Sky calibrated? '0' = Not Calibrated, '1' = Calibrated
7	('0')	1	External channels calibrated? '0' = Not Calibrated, '1' = Calibrated
8	('1')	1	Mode '0' = Automatic, '1' = Manual
9	('00223' = 22.3 dB)	5	Clear sky beacon level in 0.1dB steps
14	('00038' = 3.8 dB)	5	Clear sky offset in 0.1dB steps
19	('00121' = 12.1 dB)	5	Sampled Beacon Level in 0.1dB steps
24	('200' = 20.0 dB)	3	Compensation range in 0.1dB steps
27	('010' = 1.0 dB/dB)	3	Compensation ratio in 0.1dB/dB steps
30	('1')	1	Step size Index 0 – 4 0 = "0.1 dB" 1 = "0.2 dB" 2 = "0.5 dB" 3 = "1.0 dB" 4 = "2.0 dB"
31	('0')	1	Slew rate Index 0 – 4 "OFF" 0 = "1dB/10s" 1 = "1dB/20s" 2 = "1dB/50s" 3 = "1dB/100s"
32	('100' = 10.0 s)	3	Sample period in 0.1second steps
35	('123' = 12.3 dB)	3	Attenuation in 0.1dB steps
38	('0')	1	Scintillation enabled? '0' = Not Enabled, '1' = Enabled
39	('015' = 0.15 dB)	3	Hysteresis in 0.1dB Steps
42	('1')	1	Beacon Input *new in version 1.80 '0' = Internal tracking, '1' External beacon 'X' if UPC does not have options for internal tracking and external beacon
43	('00121' = 12.1 dB)	5	Pilot Level in 0.1dB steps *new in version 1.80 'XXXXX' if UPC does not have options for internal tracking and external beacon
48	('1')	1	UPC lock status *new in version 1.80 '0' = Not Locked, '1' = Locked
49	('525' = 52.5 dB)	3	Fade Limit level in 0.1dB steps *new in version 1.80
52	('905' = 90.5 dB)	3	Fade Limit hysteresis in 0.1dB steps *new in version 1.80
55	('XXX')	3	Not Used *new in version 1.80
58	('0')	1	Clear sky level too low fault '0' = OK '1' = FAULT
59	('0')	1	Compensation range exceeded fault '0' = OK '1' = FAULT
60	('0')	1	Missing external channels fault '0' = OK '1' = FAULT
61	('0')	1	Fade limit fault *new in version 1.80

			'0' = OK '1' = FAULT
62	('00000')	5	Not Used *new in version 1.80
67	('23/12/02 12:34:56')	17	OK Since time/date string, if there is a fault with this part of the unit then the string is blank.
84	?	1	Checksum
85	03	1	ETX

Instruction 21 (UPC Extra Information Status Request Reply (option 17d only)):

Message Byte No.	Set Value / (example)	Length (bytes)	Description
1	02	1	STX
2	?	1	No of bytes in message
3	?	1	Address
4	21	1	Message instruction
5	('A')	1	Beacon selection mode: 'M' = Manual 'A' = Automatic
6	('1')	1	Beacon input: '0' = Internal '1' = External
7	('XXXXXXXXXX')	10	Not Used
17	?	1	Checksum
18	03	1	ETX

Instruction 21 (External Beacon Status Request Reply):

This message is always for the currently selected External Beacon receiver, for normal units this is the only input available. For a unit with option 17SJ fitted, it could be either input 1 or input 2.

Message Byte No.	Set Value / (example)	Length (bytes)	Description
1	02	1	STX
2	?	1	No of bytes in message
3	?	1	Address
4	21	1	Message instruction
5	('E')	1	Device we are asking the information on: 'E' = External beacon receiver
6	('0')	1	Input Range Index 0 – 3 '0' = 0-10V '1' = +/-10V '2' = +/-5V '3' = -10-0V
7	('1')	1	Beacon slope dB/Volt Index 0 – 4 0 = 0.5 dB/Volt 1 = 1 dB/Volt 2 = 2 dB/Volt 3 = 5 dB/Volt 4 = 10 dB/Volt
8	(-1012)	5	Input voltage in 0.01V steps Eg. -10.13V = "-1013"
13	(-0205)	5	External Beacon offset in 0.1dB steps Eg. 15.4dB = "+154" (added in software version 1.38)
18	('0')	1	Out of Lock '0' = OK '1' = FAULT
19	('0')	1	Input voltage too low '0' = OK '1' = FAULT
20	('0')	1	Input voltage too high '0' = OK '1' = FAULT
21	('23/12/02 12:34:56')	17	OK Since time/date string, if there is a fault with this part of the unit then the string is blank.
38	?	1	Checksum
39	03	1	ETX

Instruction 21 (External Beacon Inputs Status Request Reply (option 17SJ only)):

Message Byte No.	Set Value / (example)	Length (bytes)	Description
1	02	1	STX
2	?	1	No of bytes in message
3	?	1	Address
4	21	1	Message instruction
5	('e')	1	Device we are asking the information on: 'e' = External beacon inputs
6	('1')	1	'1' = External Beacon input 1 '2' = External Beacon Input 2
7	('0')	1	Input Range Index 0 – 3 '0' = 0-10V '1' = +/-10V '2' = +/-5V '3' = -10-0V
8	('1')	1	Beacon slope dB/Volt Index 0 – 4 0 = 0.5 dB/Volt 1 = 1 dB/Volt

			2 = 2 dB/Volt 3 = 5 dB/Volt 4 = 10 dB/Volt
9	(-1012)	5	Input voltage in 0.01V steps Eg. -10.13V = "-1013"
14	(-0205)	5	External Beacon offset in 0.1dB steps Eg. 15.4dB = "+154"
19	(-0205)	5	External Beacon power level in 0.1dB steps Eg. 15.4dB = "+154"
24	('0')	1	Out of Lock '0' = OK '1' = FAULT
25	('0')	1	Input voltage too low '0' = OK '1' = FAULT
26	('0')	1	Input voltage too high '0' = OK '1' = FAULT
27	('23/12/02 12:34:56')	17	OK Since time/date string, if there is a fault with this part of the unit then the string is blank.
44	?	1	Checksum
45	03	1	ETX

Instruction 21 (External Beacon Inputs Status Request Reply (option 17SJ only)):

Message Byte No.	Set Value / (example)	Length (bytes)	Description
1	02	1	STX
2	?	1	No of bytes in message
3	?	1	Address
4	21	1	Message instruction
5	('e')	1	Device we are asking the information on: 'e' = External beacon inputs
6	('c')	1	'1' = External Beacon input 1 '2' = External Beacon Input 2
7	('M')	1	Mode 'M' = Manual 'A' = Automatic
8	('1')	1	Current selection '1' = Input 1 '2' = Input 2
9	?	1	Checksum
10	03	1	ETX

Instruction 21 (EXP Expansion Unit Status Request Reply):

Message Byte No.	Set Value / (example)	Length (bytes)	Description
1	02	1	STX
2	?	1	No of bytes in message
3	?	1	Address
4	21	1	Message instruction
5	('P')	1	Device we are asking the information on: 'P' = EXP expansion unit
6	('0')	1	State: 'X' = EXP Missing '-' = EXP Present
7	('01234')	5	Serial Number
12	('1')	1	PSU 1 Present 'X' = Missing '-' = Present
13	('1')	1	PSU 1 Powered '0' = Not Powered '1' Powered
14	('1')	1	PSU 2 Present 'X' = Missing '-' = Present
15	('1')	1	PSU 2 Powered '0' = Not Powered '1' Powered
16	('0')	1	Summary Alarm OK/FAULT '0' = OK '1' = FAULT
17	('0')	1	+5V voltage out of range fault '0' = OK '1' = FAULT
18	('0')	1	-15V voltage out of range fault '0' = OK '1' = FAULT
19	('0')	1	PSU Combination Voltage fault '0' = OK '1' = FAULT
20	('0')	1	Temperature out of range fault '0' = OK '1' = FAULT
21	('0')	1	PSU 1 Fault '0' = OK '1' = FAULT
22	('0')	1	PSU 2 Fault '0' = OK '1' = FAULT
23	('23/12/02 12:34:56')	17	OK Since time/date string, if there is a fault with this EXP then the string is blank. This covers the EXP channels as well as the EXP PSUs and the EXP itself.
40	?	1	Checksum
41	03	1	ETX

If the EXP is missing then the message bytes 7 to 41 (inclusive) will be all X.

Instruction 21 (Channel Status Request Reply):

Message Byte No.	Set Value / (example)	Length (bytes)	Description
1	02	1	STX
2	?	1	No of bytes in message
3	?	1	Address
4	21	1	Message instruction
5	('C')	1	Device we are asking the information on: 'C' = Channel
6	('04')	2	Channel number 01 - 16
8	('0')	1	Type Index 0 – 2 '0' = Not Used '1' = Internal '2' = External
9	('1')	1	Mode Index 0 – 2 '0' = Channel Off '1' = Automatic '2' = Manual
10	('010' = 1.0 dB/dB)	3	Compensation ratio in 0.1dB/dB steps Currently this is the compensation ratio of the entire system, in later versions this will be the compensation ratio for individual channels, allowing greater flexibility.
13	('010' = 1.0 dB)	3	Attenuation Attenuation of the channel in 0.1dB steps when in manual mode, otherwise shown as 'xxx'
16	('091' = 9.1 dB)	3	Offset Offset attenuation of the channel in 0.1dB steps, only valid when an internal channel, otherwise shown as 'xxx'
19	('1')	1	External expected unit due to it being part of the calibrated external system. '0' = Not expected, '1' = Expected If this channel is internal, 'x' is returned
20	('1')	1	External unit is missing? '0' = Not missing, '1' = Missing If this channel is internal, 'x' is returned
21	('12345')	5	External unit's serial number
26		1	Channel bypass coax switch fault For internal units with the bypass option fitted: '0' = OK '1' = FAULT If the bypass option is not fitted: '0' = OK For external units '?' as there is not a relevant fault
27	?	1	Checksum
28	03	1	ETX

Instruction 21 (EXP Expansion Unit Channel Status Request Reply):

Message Byte No.	Set Value / (example)	Length (bytes)	Description
1	02	1	STX
2	?	1	No of bytes in message
3	?	1	Address
4	21	1	Message instruction
5	('c')	1	Device we are asking the information on: 'c' = EXP Channel
6	('04')	2	Channel number 01 – 10
8	(' -')	1	State: 'X' = Channel Missing '-' = Channel Present
9	("MPC001")	27	Type of the channel
36	('1')	1	Mode Index 0 – 2 '0' = Channel Off '1' = Automatic '2' = Manual
37	('010' = 1.0 dB/dB)	3	Compensation ratio in 0.1dB/dB steps Currently this is the compensation ratio of the entire system, in later versions this will be the compensation ratio for individual channels, allowing greater flexibility.
40	('010' = 1.0 dB)	3	Attenuation Attenuation of the channel in 0.1dB steps when in manual mode, otherwise shown as 'xxx'
43	('091' = 9.1 dB)	3	Offset Offset attenuation of the channel in 0.1dB steps.
46	('XX')	2	NOT USED
48	('0')	1	Communications fault '0' = OK '1' = FAULT
49	('0')	1	Power supply fault '0' = OK '1' = FAULT
50	('0')	1	Bypass fault '0' = OK '1' = FAULT If the bypass option is not fitted: '0' = OK
51	('0')	1	RF fault '0' = OK '1' = FAULT
52	('X')	1	NOT USED
53	?	1	Checksum
54	03	1	ETX

If the EXP channel is missing then the message bytes 9 to 51 (inclusive) will be all X.

Instruction 21 (Pilot Generator Status Request Reply):

Message Byte No.	Set Value / (example)	Length (bytes)	Description
1	02	1	STX
2	?	1	No of bytes in message
3	?	1	Address
4	21	1	Message instruction
5	('i')	1	Device we are asking the information on: 'i' = Pilot generator
6	('085012500000' = 850.125MHz)	11	Frequency in Hz
17	(' -20.5' = -20.5dBm)	5	Power
22	('1')	1	Carrier ON/OFF '0' = OFF '1' = ON
23	('0' = OK)	1	Summary Alarm OK/FAULT '0' = OK '1' = FAULT
24	('0')	1	Internal comms OK/FAULT '0' = OK '1' = FAULT
25	('0')	1	Pilot Lock OK/FAULT '0' = OK '1' = FAULT
26	('23/12/02 12:34:56')	17	OK Since time/date string, if there is a fault with this part of the unit then the string is blank.
43	?	1	Checksum
44	03	1	ETX

Instruction 21 (Dual PSUs Status Request Reply):

Message Byte No.	Set Value / (example)	Length (bytes)	Description
1	02	1	STX
2	?	1	No of bytes in message
3	?	1	Address
4	21	1	Message instruction
5	('p')	1	Device we are asking the information on: 'p' = PSUs
6	('0')	1	PSU 1 – State '0' = OK, 'X' = Missing, '!' = Fault
7	('xxxxx')	5	Not Used
12	('1')	1	PSU 1 – Voltage fault '0' = OK '1' = FAULT
13	('1')	1	PSU 1 – Missing fault '0' = OK '1' = FAULT
14	('xxx')	3	Not Used
17	('0')	1	PSU 2 – State '0' = OK, 'X' = Missing, '!' = Fault
18	('xxxxx')	5	Not Used
23	('1')	1	PSU 2 – Voltage fault '0' = OK '1' = FAULT
24	('1')	1	PSU 2 – Missing fault '0' = OK '1' = FAULT
25	('xxx')	3	Not Used
28	?	1	Checksum
29	03	1	ETX

Instruction 21 (Send Composite Attenuation Status Request Reply):

Message Byte No.	Set Value / (example)	Length (bytes)	Description
1	02	1	STX
2	?	1	No of bytes in message
3	?	1	Address
4	21	1	Message instruction
5	('A')	1	Device we are asking the information on: 'A' = Composite Attenuation
6	'1'	1	Sub-extended message. Composite attenuation setting message
7	(' +123' = 12.3 dB)	4	Composite attenuation in 0.1dB steps
11	('<')	1	IF Composite Power condition, used in combination with the IF Composite Power field, e.g. < -50dBm Possible values are: '<' – less than '>' – greater than '=' - equals
12	(' -0500' = -50.0 dBm)	5	IF Composite Power in 0.1dBm steps
17	('0')	1	IF Compression Warning '0' = OK '1' = WARNING
18	?	1	Checksum
19	03	1	ETX

Instruction 21 (RF Paths):

Message Byte No.	Set Value / (example)	Length (bytes)	Description
1	02	1	STX
2	?	1	No of bytes in message
3	?	1	Address
4	21	1	Message instruction
5	('F')	1	'F' = RF Paths
6	('1')	1	RF Input path '1' = Path 1 '2' = Path 2
7	('10123456789' = 10.123456789 GHz)	11	Frequency in Hz The frequency of the unit.
Path 1 Settings			
18	(' +0123' = 12.3 dB)	5	Gain in 0.1dB steps
23	('1')	1	10MHz ON/OFF '0' = OFF '1' = ON
24	('1')	1	DC Feed ON/OFF '0' = OFF '1' = ON
25	('01')	2	DC Feed Voltage '01' = 13.0V '02' = 13.3V '03' = 13.7V '04' = 14.0V '05' = 14.3V '06' = 14.7V '07' = 15.0V '08' = 18.0V '09' = 18.5V '10' = 18.8V '11' = 19.2V '12' = 19.5V '13' = 19.8V '14' = 20.0V '15' = 20.5V *new in version 2.00
27	('1')	1	22kHz Tone ON/OFF

			'0' = OFF '1' = ON
28	('XXXX')	4	Not Used
Path 2 Settings			
32	('+0123' = 12.3 dB)	5	Gain in 0.1dB steps
37	('1')	1	10MHz ON/OFF '0' = OFF '1' = ON
38	('1')	1	DC Feed ON/OFF '0' = OFF '1' = ON
39	('01')	2	DC Feed Voltage '01' = 13.0V '02' = 13.3V '03' = 13.7V '04' = 14.0V '05' = 14.3V '06' = 14.7V '07' = 15.0V '08' = 18.0V '09' = 18.5V '10' = 18.8V '11' = 19.2V '12' = 19.5V '13' = 19.8V '14' = 20.0V '15' = 20.5V *new in version 2.00
41	('1')	1	22kHz Tone ON/OFF '0' = OFF '1' = ON
42	('XXXX')	4	Not Used
46	?	1	Checksum
47	03	1	ETX

Instruction 21 (DC Output Limits):

Message Byte No.	Set Value / (example)	Length (bytes)	Description
1	02	1	STX
2	?	1	No of bytes in message
3	?	1	Address
4	21	1	Message instruction
5	('L')	1	'L' = DC Output Limits
6	('0')	1	Lower Limit '0' = 0 Volts '1' = -5 Volts '2' = -10 Volts
7	('0')	1	Lower Limit '0' = 0 Volts '1' = +5 Volts '2' = +10 Volts
8	?	1	Checksum
9	03	1	ETX

Instruction 22 (UPC Request Settings Change):

Message Byte No.	Set Value / (example)	Length (bytes)	Description
1	02	1	STX
2	?	1	No of bytes in message
3	?	1	Address
4	22	1	Message instruction
5	('U')	1	Device we are asking to change the settings of: 'U' = UPC
6	('0')	1	Clear Sky Calibrated? '0' = Not Calibrated, '1' = Calibrated
7	('0')	1	External channels calibrated? '0' = Not Calibrated, '1' = Calibrated
8	('1')	1	Mode '0' = Automatic, '1' = Manual
9	('00038' = 3.8 dB)	5	Clear sky offset in 0.1dB steps
14	('200' = 20.0 dB)	3	Compensation range in 0.1dB steps
17	('010' = 1.0 dB/dB)	3	Compensation ratio in 0.1dB/dB steps
20	('1')	1	Step size Index 0 – 4 0 = "0.1 dB" 1 = "0.2 dB" 2 = "0.5 dB" 3 = "1.0 dB" 4 = "2.0 dB"
21	('0')	1	Slew rate Index 0 – 4 0 = "OFF" 1 = "1dB/10s" 2 = "1dB/20s" 3 = "1dB/50s" 4 = "1dB/100s"
22	('100' = 10.0 s)	3	Sample period in 0.1second steps
25	('123' = 12.3 dB)	3	Attenuation in 0.1dB steps, only changeable when in manual mode
28	('0')	1	Scintillation enabled? '0' = Not Enabled, '1' = Enabled
29	('015' = 1.5 dB)	3	Hysteresis in 0.1dB steps *new in version 1.16 For backwards compatibility this can be removed from the remote control by turning off the UPC 'Remote Hysteresis' option in the Modify Parameters menu.
32	('1')	1	Beacon Input *new in version 1.80 '0' = Internal tracking, '1' External beacon Ignored if UPC does not have options for internal tracking and external beacon
33	('525' = 52.5 dB)	3	Fade Limit level in 0.1dB steps *new in version 1.80
36	('905' = 90.5 dB)	3	Fade Limit hysteresis in 0.1dB steps *new in version 1.80
39	?	1	Checksum
40	03	1	ETX

Instruction 22 (UPC Extra Information Change Request (option 17d only)):

Message Byte No.	Set Value / (example)	Length (bytes)	Description
1	02	1	STX
2	?	1	No of bytes in message
3	?	1	Address
4	21	1	Message instruction
5	('A')	1	Beacon selection mode: 'M' = Manual 'A' = Automatic
6	('1')	1	Beacon input: '0' = Internal '1' = External
7	?	1	Checksum
8	03	1	ETX

Instruction 22 (Tracking Settings Change Request [L-Band Beacon Input]):

Message Byte No.	Set Value / (example)	Length (bytes)	Description
1	02	1	STX
2	?	1	No of bytes in message
3	?	1	Address
4	21	1	Message instruction
5	('K')	1	Device we are asking the information on: 'K' = Tracking
6	('01202000000' = 01.202000000 GHz)	11	Video Centre Frequency in Hz
17	('20000000' = 20MHz)	8	Frequency Span in Hz Span max 25MHz
25	('080' = -80dB)	4	Video Reference Level in dB Range: -80dB to -100dB in 5dB steps
29	('1')	1	Band Width Resolution in kHz 1 = 1 kHz, 6 = 6 kHz
30	('1')	1	10 dB Pad ON/OFF '0' = OFF '1' = ON
31	('1')	1	Sweep Rate Index 0 – 7 0 = "2.5 kHz/s" 1 = "5 kHz/s", 2 = "10 kHz/s", 3 = "20 kHz/s", 4 = "40 kHz/s", 5 = "80 kHz/s" 6 = "120 kHz/s" 7 = "240 kHz/s"
32	('1')	1	Sweep Width Index 0 – 4 0 = "+/- 20 kHz" 1 = "+/- 50 kHz" 2 = "+/- 100 kHz" 3 = "+/- 200 kHz" 4 = "+/- 500 kHz"
33	('1')	1	Log dB/Volt Index 0 – 4 0 = 0.5 dB/Volt 1 = 1 dB/Volt 2 = 2 dB/Volt 3 = 5 dB/Volt 4 = 10 dB/Volt
34	('080')	3	Log Offset 000 – 100.
37	('0')	1	ASB ON/OFF '0' = OFF '1' = ON

38	('10123456789' = 10.123456789 GHz)	11	The frequency of the unit in Hz
49	('+0123' = 12.3 dB)	5	Gain in 0.1dB steps
54	('X')	1	Not used
55	('1')	1	10MHz ON/OFF '0' = OFF '1' = ON
56	('1')	1	DC Feed ON/OFF '0' = OFF '1' = ON
57	('01')	2	DC Feed Voltage '01' = 13.0V '02' = 13.3V '03' = 13.7V '04' = 14.0V '05' = 14.3V '06' = 14.7V '07' = 15.0V '08' = 18.0V '09' = 18.5V '10' = 18.8V '11' = 19.2V '12' = 19.5V '13' = 19.8V '14' = 20.0V '15' = 20.5V *new in version 2.00
59	('1')	1	22kHz Tone ON/OFF '0' = OFF '1' = ON *new in version 2.00
60	('1')	1	SHF LO ON/OFF '0' = OFF '1' = ON
61	('20123456789' = 20.123456789 GHz)	11	SHF Frequency in Hz
72	('1')	1	SHF Spectrum Invert ON/OFF '0' = OFF '1' = ON
73	?	1	Checksum
74	03	1	ETX

Instruction 22 (Tracking Settings Change Request [L-Band Beacon Input]):

Message Byte No.	Set Value / (example)	Length (bytes)	Description
1	02	1	STX
2	?	1	No of bytes in message
3	?	1	Address
4	21	1	Message instruction
5	('K')	1	Device we are asking the information on: 'K' = Tracking
6	('01202000000' = 01.202000000 GHz)	11	Video Centre Frequency in Hz
17	('20000000' = 20MHz)	8	Frequency Span in Hz Span max 25MHz
25	(' -080' = -80dB)	4	Video Reference Level in dB Range: -80dB to -100dB in 5dB steps
29	('1')	1	Band Width Resolution in kHz 1 = 1 kHz, 6 = 6 kHz
30	('1')	1	10 dB Pad ON/OFF '0' = OFF '1' = ON
31	('1')	1	Sweep Rate Index 0 – 7 0 = "2.5 kHz/s" 1 = "5 kHz/s", 2 = "10 kHz/s", 3 = "20 kHz/s", 4 = "40 kHz/s", 5 = "80 kHz/s" 6 = "120 kHz/s" 7 = "240 kHz/s"
32	('1')	1	Sweep Width Index 0 – 4 0 = "+/- 20 kHz" 1 = "+/- 50 kHz" 2 = "+/- 100 kHz" 3 = "+/- 200 kHz" 4 = "+/- 500 kHz"
33	('1')	1	Log dB/Volt Index 0 – 4 0 = 0.5 dB/Volt 1 = 1 dB/Volt 2 = 2 dB/Volt 3 = 5 dB/Volt 4 = 10 dB/Volt
34	('080')	3	Log Offset 000 – 100.
37	('0')	1	ASB ON/OFF '0' = OFF '1' = ON
38	('10123456789' = 10.123456789 GHz)	11	The frequency of the unit in Hz
49	('+0123' = 12.3 dB)	5	Gain in 0.1dB steps
54	('X')	1	Not used
55	('X')	1	Not used
56	('X')	1	Not used
57	('X')	2	Not used *new in version 2.00
59	('X')	1	Not used *new in version 2.00
60	('X')	1	Not used
61	('XXXXXXXXXXXXX')	11	Not used
72	('X')	1	Not used
73	?	1	Checksum
74	03	1	ETX

Instruction 22 (Channel Settings Change Request):

Message Byte No.	Set Value / (example)	Length (bytes)	Description
1	02	1	STX
2	?	1	No of bytes in message
3	?	1	Address
4	22	1	Message instruction
5	('C')	1	Device we are asking the information on: 'C' = Channel
6	('04')	2	Channel number
9	('1')	1	Mode Index 0 – 2 '0' = Channel Off '1' = Automatic '2' = Manual
10	('xxx')	3	Currently not used
13	('010' = 1.0 dB)	3	Attenuation Attenuation of the channel in 0.1dB steps when in manual mode, otherwise this setting is ignored
16	('091' = 9.1 dB)	3	Offset Offset attenuation of the channel in 0.1dB steps, only valid when an internal channel otherwise this setting is ignored
19	?	1	Checksum
20	03	1	ETX

Instruction 22 (External Beacon Settings Change Request):

Message Byte No.	Set Value / (example)	Length (bytes)	Description
1	02	1	STX
2	?	1	No of bytes in message
3	?	1	Address
4	22	1	Message instruction
5	('E')	1	Device we are asking the information on: 'E' = External beacon receiver
6	('0')	1	Input Range Index 0 – 3 '0' = 0-10V '1' = +/-10V '2' = +/-5V '3' = -10-0V
7	('1')	1	Beacon slope dB/Volt Index 0 – 4 0 = 0.5 dB/Volt 1 = 1 dB/Volt 2 = 2 dB/Volt 3 = 5 dB/Volt 4 = 10 dB/Volt
8	(-0205)	5	External Beacon offset in 0.1dB steps eg. 15.4dB = "+154" (added in software version 1.38)
13	?	1	Checksum
14	03	1	ETX

Instruction 22 (External Beacon Inputs Status Request Reply (option 17SJ only)):

Message Byte No.	Set Value / (example)	Length (bytes)	Description
1	02	1	STX
2	?	1	No of bytes in message
3	?	1	Address
4	22	1	Message instruction
5	('e')	1	Device we are asking the information on:

			'e' = External beacon receiver
6	('1')	1	'1' = External Beacon input 1 '2' = External Beacon Input 2
7	('0')	1	Input Range Index 0 – 3 '0' = 0-10V '1' = +/-10V '2' = +/-5V '3' = -10-0V
8	('1')	1	Beacon slope dB/Volt Index 0 – 4 0 = 0.5 dB/Volt 1 = 1 dB/Volt 2 = 2 dB/Volt 3 = 5 dB/Volt 4 = 10 dB/Volt
9	(-0205)	5	External Beacon offset in 0.1dB steps eg. 15.4dB = "+154"
14	?	1	Checksum
15	03	1	ETX

Instruction 22 (External Beacon Inputs Change Request (option 17SJ only)):

Message Byte No.	Set Value / (example)	Length (bytes)	Description
1	02	1	STX
2	?	1	No of bytes in message
3	?	1	Address
4	22	1	Message instruction
5	('e')	1	Device we are asking the information on: 'e' = External beacon inputs
6	('c')	1	'c' = Configuration
7	('M')	1	Mode 'M' = Manual 'A' = Automatic
8	('1')	1	Current selection '1' = Input 1 '2' = Input 2
9	?	1	Checksum
10	03	1	ETX

Instruction 22 (EXP Expansion Unit Channel Settings Change Request):

Message Byte No.	Set Value / (example)	Length (bytes)	Description
1	02	1	STX
2	?	1	No of bytes in message
3	?	1	Address
4	22	1	Message instruction
5	('c')	1	Device we are asking the information on: 'c' = EXP Channel
6	('04')	2	Channel number
8	('1')	1	Mode Index 0 – 2 '0' = Channel Off '1' = Automatic '2' = Manual
9	('xxx')	3	Currently not used
12	('010' = 1.0 dB)	3	Attenuation Attenuation of the channel in 0.1dB steps when in manual mode, otherwise this setting is ignored
15	('091' = 9.1 dB)	3	Offset Offset attenuation of the channel in 0.1dB steps, only valid when an internal channel otherwise this setting is ignored
18	?	1	Checksum
19	03	1	ETX

Instruction 22 (Pilot Generator Setting Change Request):

Message Byte No.	Set Value / (example)	Length (bytes)	Description
1	02	1	STX
2	?	1	No of bytes in message
3	?	1	Address
4	21	1	Message instruction
5	('i')	1	Device we are asking the information on: 'i' = Pilot generator
6	('085012500000' = 850.125MHz)	11	Frequency in Hz
17	(' -20.5' = -20.5dBm)	5	Power
22	('1')	1	Carrier ON/OFF '0' = OFF '1' = ON
23	?	1	Checksum
24	03	1	ETX

Instruction 22 (Composite IF Attenuation Reconfiguration Request Reply):

Message Byte No.	Set Value / (example)	Length (bytes)	Description
1	02	1	STX
2	?	1	No of bytes in message
3	?	1	Address
4	21	1	Message instruction
5	'A'	1	'A' = Composite Attenuation
6	(' +123' = 12.3 dB)	4	Composite attenuation in 0.1dB steps
10	?	1	Checksum
11	03	1	ETX

Instruction 22 (RF Paths):

Message Byte No.	Set Value / (example)	Length (bytes)	Description
1	02	1	STX
2	?	1	No of bytes in message
3	?	1	Address
4	22	1	Message instruction
5	('F')	1	'F' = RF Paths
6	('1')	1	RF Input path '1' = Path 1 '2' = Path 2
7	('10123456789' = 10.123456789 GHz)	11	Frequency in Hz The frequency of the unit.
Path 1 Settings			
18	('+0123' = 12.3 dB)	5	Gain in 0.1dB steps
23	('1')	1	10MHz ON/OFF '0' = OFF '1' = ON
24	('1')	1	DC Feed ON/OFF '0' = OFF '1' = ON
25	('01')	2	DC Feed Voltage '01' = 13.0V '02' = 13.3V '03' = 13.7V '04' = 14.0V '05' = 14.3V '06' = 14.7V '07' = 15.0V '08' = 18.0V '09' = 18.5V '10' = 18.8V '11' = 19.2V '12' = 19.5V '13' = 19.8V '14' = 20.0V '15' = 20.5V *new in version 2.00
27	('1')	1	22kHz Tone ON/OFF '0' = OFF '1' = ON
28	('XXXX')	4	Not Used
Path 2 Settings			
32	('+0123' = 12.3 dB)	5	Gain in 0.1dB steps
37	('1')	1	10MHz ON/OFF '0' = OFF '1' = ON
38	('1')	1	DC Feed ON/OFF '0' = OFF '1' = ON
39	('01')	2	DC Feed Voltage '01' = 13.0V '02' = 13.3V '03' = 13.7V '04' = 14.0V '05' = 14.3V '06' = 14.7V '07' = 15.0V '08' = 18.0V '09' = 18.5V '10' = 18.8V '11' = 19.2V '12' = 19.5V '13' = 19.8V '14' = 20.0V '15' = 20.5V *new in version 2.00
41	('1')	1	22kHz Tone ON/OFF

			'0' = OFF '1' = ON
42	('XXXX')	4	Not Used
46	?	1	Checksum
47	03	1	ETX

If the unit does not have dual paths, then the Path 2 settings are all X's. Changing the settings in this message for the currently selected path, is the same as changing them in the normal 'K' configuration message.

Instruction 22 (DC Output Limits):

Message Byte No.	Set Value / (example)	Length (bytes)	Description
1	02	1	STX
2	?	1	No of bytes in message
3	?	1	Address
4	21	1	Message instruction
5	('L')	1	'L' = DC Output Limits
6	('0')	1	Lower Limit '0' = 0 Volts '1' = -5 Volts '2' = -10 Volts
7	('0')	1	Lower Limit '0' = 0 Volts '1' = +5 Volts '2' = +10 Volts
8	?	1	Checksum
9	03	1	ETX

Instruction 24 (Set Remote/Local Mode):

Message Byte No.	Set Value / (example)	Length (bytes)	Description
1	02	1	STX
2	?	1	No of bytes in message
3	?	1	Address
4	24	1	Message instruction
5	('R')	1	'R' = Remote Mode 'L' = Local Mode
6	?	1	Checksum
7	03	1	ETX

The unit MUST be in remote mode to allow reconfiguration of parameters via the remote control.

Alarm Log message routines & Remote Interrogation of the Alarms log.

The unit will remember the number of new LOG entries that have been added since the user last requested LOG entry status.

If instruction 30 is sent, it will respond with the number of new LOG items since the last request.

Instruction 36 can be sent to get the list of currently unread LOG items, when there are no more unread LOG items the unit will respond with *!END!*.

Alternatively, the user can ask for LOG item [n] using instruction 32.

Instruction 30 (Alarm Log Entry Status Request):

Message Byte No.	Set Value / (example)	Length (bytes)	Description
1	02	1	STX
2	?	1	No of bytes in message
3	?	1	Address
4	30	1	Message instruction
5	?	1	Checksum
6	03	1	ETX

Instruction 31 (Alarm Log Entry Status Response):

Message Byte No.	Set Value / (example)	Length (bytes)	Description
1	02	1	STX
2	?	1	No of bytes in message
3	?	1	Address
4	31	1	Message instruction
5	('010')	3	No. of Log entries
8	('001')	3	No of Log entries that are NEW since the last Log Entry Status Request.
11	?	1	Checksum
12	03	1	ETX

Instruction 32 (Alarm Log Entry Request):

Message Byte No.	Set Value / (example)	Length (bytes)	Description
1	02	1	STX
2	?	1	No of bytes in message
3	?	1	Address
4	32	1	Message instruction
5	('002' = ask for log entry 2)	3	No. of the LOG entry to be returned
8	?	1	Checksum

9	03	1	ETX
---	----	---	-----

Instruction 33 (Alarm Log Entry Response):

Message Byte No.	Set Value / (example)	Length (bytes)	Description
1	02	1	STX
2	?	1	No of bytes in message
3	?	1	Address
4	33	1	Message instruction
5	("LOG Entry 001 of 124*Unit: +36V Fault*31.6V*23/12/04 12:23:45*")	?	Details of the LOG message Should be the same as what is displayed on screen, each line is ended with a *. LOG entry number x of n* Unit: Fault type* Extra Fault details* Date and Time*
?	?	1	Checksum
?	03	1	ETX

Instruction 34 (Clear Alarm Log Request):

Message Byte No.	Set Value / (example)	Length (bytes)	Description
1	02	1	STX
2	?	1	No of bytes in message
3	?	1	Address
4	34	1	Message instruction
5	?	1	Checksum
6	03	1	ETX

Instruction 36 (Next Unread Alarm Log Item Request):

Message Byte No.	Set Value / (example)	Length (bytes)	Description
1	02	1	STX
2	?	1	No of bytes in message
3	?	1	Address
4	36	1	Message instruction
5	?	1	Checksum
6	03	1	ETX

Instruction 37 (Next Unread Alarm Log Item Response):

Message Byte No.	Set Value / (example)	Length (bytes)	Description
1	02	1	STX
2	?	1	No of bytes in message
3	?	1	Address
4	37	1	Message instruction
5	("LOG Entry 001 of 124*Unit: +36V Fault*31.6V*23/12/04 12:23:45*")	?	Details of the NEXT previously unread LOG message. Should be the same as what is displayed on screen, each line is ended with a *. LOG entry number x of n* Unit: Fault type* Extra Fault details* Date and Time* If no more unread LOG message the text sent back is "!END*"
?	?	1	Checksum
?	03	1	ETX

Instruction 40 (Unit Status Request):

Message Byte No.	Set Value / (example)	Length (bytes)	Description
1	02	1	STX
2	?	1	No of bytes in message
3	?	1	Address
4	40	1	Message instruction
5	?	1	Checksum
7	03	1	ETX

Instruction 41 (Unit Status Request Reply):

Message Byte No.	Set Value / (example)	Length (bytes)	Description
1	02	1	STX
2	?	1	No of bytes in message
3	?	1	Address
4	41	1	Message instruction
5	('UPC7000')	27	Type of unit this is: P7000, P7001 etc
32	('01234' = Serial No 01234)	5	Serial Number
37	('0112.34')	7	Software Version Number
44	('0' = OK)	1	Summary Alarm OK/FAULT '0' = OK '1' = FAULT
45	('0')	1	+5V voltage out of range fault '0' = OK '1' = FAULT
46	('0')	1	+15V voltage out of range fault '0' = OK '1' = FAULT
47	('0')	1	-15V voltage out of range fault '0' = OK '1' = FAULT
48	('0')	1	Primary voltage out of range fault '0' = OK '1' = FAULT
49	('0')	1	Temperature out of range fault '0' = OK '1' = FAULT
50	('0')	1	Humidity out of range fault '0' = OK '1' = FAULT
51	('0')	1	External Reference fault '0' = OK '1' = FAULT
52	('0')	1	100MHz fault '0' = OK '1' = FAULT
53	('0')	1	Coax Switch fault '0' = OK '1' = FAULT
54	('0')	1	Internal ethernet module fault '0' = OK '1' = FAULT
55	('23/12/02 12:34:56')	17	OK Since time/date string, if there is a fault with this down/up part of the converter then the string is blank.
72	('0')	1	1:1 Status '0' = Offline '1' = Online
73	('0')	1	Remote mode '0' = Local '1' = Remote
74	('0')	1	External Reference '0' = Off '1' = On
75	?	1	Checksum
76	03	1	ETX

Instruction 45 (Redundancy Status Request):

Message Byte No.	Set Value / (example)	Length (bytes)	Description
1	02	1	STX
2	?	1	No of bytes in message
3	?	1	Address
4	45	1	Message instruction
5	?	1	Checksum
7	03	1	ETX

Instruction 46 (Redundancy Status Request Reply):

Message Byte No.	Set Value / (example)	Length (bytes)	Description
1	02	1	STX
2	?	1	No of bytes in message
3	?	1	Address
4	46	1	Message instruction
5	('1')	1	Redundancy Type Configuration '1' = 1 for 1
6	('M')	1	Redundancy Manual Mode 'M' = Manual 'A' = Auto
7	('0')	1	Online Status '0' = Offline '1' = Online
8	('A')	1	Unit Identifier 'A' or 'B'
9	('X')	1	NOT USED
10	('A')	1	Unit Online 'A' or 'B' when in 1 for 1 configuration. 'A' or 'B' or 'S' when in 1 for 2 configurations and the unit selected as standby otherwise 'X' '@' means no redundant controller attached, unit online not known.
11	('1')	1	Coax Switch Position '1' or '2' '0' means no redundant controller attached, position not known Used for 1 for 1, 1 for 2 configurations, irrelevant in 1 for N configuration.
12	('00')	2	NOT USED
14	('1')	1	Redundancy control status '0' = Normal operation '1' = Under redundancy control
15	?	1	Checksum

Instruction 47 (Redundancy Change Request):

The 'unit to go online' parameter can only be modified when it is being changed on the currently offline unit.

Message Byte No.	Set Value / (example)	Length (bytes)	Description
1	02	1	STX
2	?	1	No of bytes in message
3	?	1	Address
4	47	1	Message instruction
5	('M')	1	Redundancy Mode 'M' = Manual 'A' = Auto
6	('S')	1	Unit to go Online 'A' or 'B' when in 1 for 1 configuration
7	?	1	Checksum
8	03	1	ETX

5.2 Remote control version

V1.39 and later software is now able to emulate a previous software version's remote control this is to eliminate the need for software driver updates due to changes in the current version's remote-control specification. This should hopefully reduce customer's requirements to keep updating their drivers when new features are added to the unit.

The table below shows the differences between the remote-control messages and their versions, not all remote control messages are covered by this versioning as they have never been changed and hence are not of this list.

Message	Version	Changes
External Beacon Status P7xxx – Msg 21	1.00	Created
	1.38	External beacon offset added
UPC Status Request P7xxx - Msg 21	1.00	Created
	1.16	Hysteresis added
	1.68	Scintillation included for all messages. Clear Sky offset added
	1.80	Beacon Input Pilot Level UPC lock Fade Limit Fade Limit hysteresis 3 spare bytes Fade Limit fault 5 spare faults added
	2.00	DC Feed Voltage, and 22kHz tone added
UPC Request Settings Change P7xxx - Msg 22	1.00	Created
	1.16	Hysteresis added
	1.68	Scintillation included for all messages. Clear Sky offset added
	1.80	Beacon Input Fade Limit Fade Limit hysteresis added

5.3 Ethernet remote control (Optional)

The Ethernet option for the UPC7000 series products adds the ability to control the unit by Ethernet as well as by the existing standard RS232 or RS485, this is achieved via a separate module within the unit.

The unit can be controlled through the Ethernet port using three different approaches.

TCP Port

The unit can be controlled using the serial remote-control messages as described earlier sent through the TCP port set in the Ethernet menu option.

Web Page

The unit can be controlled via the in-built web server's web page. There are two pages, Status and Configure. Hopefully both of which are self-explanatory. Figures 13 & 14 show sample screen shots of the web pages (these may not be representative of the model in this manual).



Figure 13



Figure 14

SNMP

Units fitted with Ethernet, have a built-in SNMP (Simple Network Management Protocol) agent software.

It supports SNMP Trap, RFC1155, 1157, 1212, 1213, 1901 & 1906, as well as the Peak MIBS.

The Peak SNMPv2 MIB files are supplied by Peak Communications Ltd, below is a quick overview of them.

The Peak Enterprises node is essentially split into three main areas:

Converters - In this node there is a peakxxxxxxxxxxxxxxxxModule showing a table of the Converter module(s), this is where the band of the unit can be checked/changed.

Unit – This node allows the unit status to be checked as well as the Ethernet and redundancy settings.

PeakFaultsModule – This node contains the unit summary alarm as well as a table showing all the faults currently on the unit.

APPENDIX 1 Terms and conditions of sale

Peak Communications Ltd

Terms and Conditions of Sale

1 Application of Terms and Conditions

The following terms and conditions shall constitute the entire agreement between Peak Communications Limited ("the Seller") and the purchaser of any goods or services ("the Customer) from the Seller. No contract shall be formed between the Seller and the Customer until the dispatch by the Seller to the Customer of the Seller's written acknowledgment of order. Unless otherwise expressly agreed in writing by the Seller, these conditions shall apply to all quotations and invoices given, orders received and accepted and contracts undertaken by the Seller. All prices quoted by the Seller are based upon these Conditions of Sale and reflect the limitations upon the Seller's liability which they contain. No modifications of these terms and conditions shall have effect unless agreed in writing by the Seller and shall not be affected by any documentation or communication from the Customer purporting to give effect to different terms and/or conditions.

2 Invoicing and Payment Terms

a) Unless otherwise expressly agreed in writing between the Customer and the Seller, the Seller shall be entitled to invoice the Customer for the price of goods on delivery of the goods, unless the goods are to be collected by the Customer (or their agent) or the Customer wrongfully fails to take delivery of the goods, in which event the Seller shall be entitled to invoice the Customer for the price at any time after the Seller has notified the Customer that the goods are ready for collection or (as the case may be) the Seller has tendered delivery of the goods.

b) Charges for services will be invoiced on completion of the services.

c) Where credit terms are allowed by the Seller to the Customer, the terms of payment of all invoices issued by the Seller to the Customer are, unless otherwise decreed in writing, to be paid net at the Seller's registered office within 30 days from the date of the invoice unless otherwise stated on the invoice and subject to condition (d) below. Where credit terms are not given by the Seller, a pro-forma invoice will be issued by the Seller and goods will be dispatched on payment.

d) Notwithstanding condition ©, the Seller shall without prejudice to its other rights, have the right by notice in writing to the Customer to demand immediate payment of all monies due from the Customer to the Seller for goods delivered at whatever time. The Seller also reserves the right to ask for a payment of a deposit before acceptance of an order.

e) The Seller reserves the right to charge interest on all or any sums not paid within 30 days from the date of invoice at the rate of 2% of the total invoiced amount for every period of 30 days (and pro rata for any part of a period of 30 days whether before or after judgment) from the due date of payment until the date of actual receipt of payment in full by the Seller.

f) The Customer shall indemnify the Seller against any loss or expense sustained or incurred by the Seller as a result of any change in currency exchange rates or in exchange control or other governmental regulations by reason of or in connection with any failure on the part of the Customer to pay any sum payable hereunder within 30 days of the date of the invoice,

g) The Seller shall have the right to invoice the Customer for part delivery or provision of goods or services to the Customer notwithstanding the fact that other goods or services are to be delivered or provided to the Customer under the contract.

h) The Seller's rights under this paragraph (2) shall be exercisable in addition to all and any other rights the Seller may have under these Terms and Conditions of Sale.

i) All sums owing to the Seller to the Customer shall be paid in full without any objection, set off or counterclaim, save in respect of mutual debts and set off which cannot be excluded by reason of statute

3 Prices

a) The price of goods shall be the price ruling at the date of delivery unless otherwise stated on the quotation invoice, or previously agreed in writing by the seller. The prices are based on the costs of packing, documentation, insurance and any other costs incurred by the Seller, prior to dispatch from the Sellers works, but excludes all customs duties levies and freight charges.

b) All prices quoted in writing or by fax by the Seller to the Customer shall have a validity of 30 days unless otherwise expressly stated on the specific quotation. Thereafter the price must be revalidated in writing or by fax by the Seller to the Customer at the Customer's request.

c) The Seller reserves the right to alter its prices, its published terms of trade and its catalogue and other published material at any time and without prior notice.

d) The Seller reserves the right to alter its quoted prices during the course of a contract for the supply of goods or services in that contract to reflect changes in;

(i) VAT, Duty and other levies brought about by changes in governmental legislation.

(ii) Costs brought about by exchange rate fluctuations or changes in manufacturers' list price.

4 Specification

a) Goods are manufactured to the specifications as published within the Sellers documentation. Particular specifications not mentioned in the documentation will be quoted prior to order acceptance at the request of the Customer. Any specifications not agreed at acceptance of order will not form part of any contract or warranty claim.

b) If the goods are to be manufactured or any process is to be applied to the goods by the Seller in accordance with a specification submitted by the Customer, the Customer shall indemnify the Seller against all loss, damages, costs and expenses arising out of or in connection with or paid or agreed to be paid by the Seller in settlement of any claim or infringement of any patent, copyright, design, trade mark or other industrial or intellectual property rights of any other person which results from the Seller's use of the Customer's specification.

c) The Customer shall be responsible for stipulating the specifications of goods to be supplied by the Seller and the Seller accepts no responsibility where the Customer has incorrectly stipulated required specifications, where the specification stipulated is not suitable for the Customer's actual requirements. The Seller will however on request provide advice in relation to the suitability of different specifications of goods for the purposes identified by the Customer, although any such advice is provided for guidance only and the Customer accepts ultimate responsibility for the suitability for the Customer's actual requirements on the specification of the goods stipulated by the Customer. The Customer shall also have responsibility for ensuring that the capacity and performance of the goods are specified in its order and are sufficient and suitable for its purpose

d) The Seller reserves the right to make any changes in the specification of the goods which are required to conform with any applicable statutory or EC regulatory requirements or, where the goods are to be supplied to the Seller's specification, which do not materially affect their quality or performance.

e) The Seller reserves the right, if extra expense or nay increase in costs or overheads are incurred by the Seller as a result of modifications made at the Customer's request, the Customer's special requirements or instructions, or the failure of the Customer to supply drawings, plans, specifications or any other information whatsoever to enable to the Seller to proceed with the Contract, to increase the price by giving notice in writing of the amount of such increase to the Customer

f) Goods are manufactured and dispatched to comply with Customer's Order as interpreted by the Seller. Any costs for changes arising, due to interpretation of the order, are at the Customers expense.

g) At the time of acceptance of the specification submitted by the Customer the Seller will give an estimate of the risk involved in achieving the Customer Specification. If any deviation from the customers Specification is found during development and manufacture, the Customer will be informed within 7 days.

5 Title and Risk

a) Risk in the goods shall pass to the Customer when delivery is made to the customer or its agents, subcontractors or carriers except that, where the goods are to be delivered at the Seller's premises, risk in the goods shall pass at the time when the Seller notifies the Customer that the goods are ready for collection.

b) All the goods shall remain the sole and absolute property of the Seller until such a time as the Customer shall have paid to the Seller the agreed price together with the full price of any other goods the subject of any other contract with the Seller.

c) The Customer acknowledges that the Customer is in possession of goods solely as bailee for the Seller until such time as the full price thereof is paid to the Seller together with the full price of any other goods the subject of any other contract with the Seller.

d) The Customer's right to possession of the goods shall cease if-

(i) The Seller serves notice requiring that the goods be returned; or

(ii) In the case of an individual, he commits an available act of bankruptcy or proposes to enter into a voluntary arrangement with his creditors; or

(iii) In the case of a company:-

It is unable to pay its debtors for the purposes of S 123 of the Insolvency Act 1986; or a Receiver or Administrative Receiver is appointed; or a Petition for an Administration Order is presented or an Administrator appointed; or

The Customer proposes an informal arrangement with its creditors or a formal corporate voluntary arrangement; or

The Customer takes any step to enter into a voluntary liquidation, or if a Liquidator is appointed, or if a Petition for the winding up of the Customer is presented; or In the event that the Customer is not a

company incorporated in England, any event analogous to those specified above shall occur in relation to the Customer. Until such time as the Customer becomes the owner of the goods, the Customer will store them on his premises separately from the Customer's own goods or those of any other person and in a manner which makes them readily identifiable as the goods of the Seller.

e) If any of the events listed at d(ii) and (iii) above occur in relation to the Customer (or any parent of the Customer), or in the event that the Customer is not a company incorporated in England, any events analogous to those specified in d(ii) or (iii) occur, and then and in any such events or such events or sums due or becoming due by the Customer to the Seller shall forthwith and without notice immediately become due and payable in full. In addition, the Seller shall have the right at its discretion to decline to perform any contract in whole or in part then not performed by the Seller in whole or in part without prejudice to all and any of the rights it may have under the terms and conditions of sale.

6 Cancellation of Order

a) If the Customer shall fail to pay to the Seller on the due date any sum payable hereunder or shall exceed its credit limit or breach the terms upon which such credit has been offered or shall suffer any of the events listed in Condition 5d)(ii) (being an individual) or 5d)(iii) (being a company) the Seller may, without prejudice to its other rights, and without prejudice to the generality of Condition 2(d) demand immediate payment by the Customer of all unpaid accounts and, in addition, and suspend or cancel further deliveries and cancel this and any other contract between the Seller and the Customer without any liability attaching to the Seller in respect of such suspension or cancellation and debit the Customer with any loss sustained thereby.

b) The Seller will only accept a cancellation or postponement of any order by or on behalf of the Customer or any refusal to accept delivery if the Customer pays the amount specified by the Seller as representing its losses incurred thereby. Without prejudice to the generality of the foregoing the Seller will not accept cancellations of, and the Customer will be obliged at all times to purchase, materials which have already been manufactured or which have been modified or specifically purchased to meet the Customer's requirements. Any amount owing by the Seller to the Customer as a result of any properly cancelled order will be satisfied by the Seller issuing credit notes to the Customer to a value equal to the amount owing.

7 Insurance of Goods in Transit

a) The Seller will insure the goods for a total invoice price to the Customer if transport is agreement to be effected by the Seller or its agent. Where the Seller insures goods the liability of the Seller shall be absolutely limited to the amount if any received by the Seller under such insurance from its insurers from which a reasonable deduction may be made for administrative expenses.

b) If the Customer arranges transport either directly or indirectly through its agents the Customer must insure the goods against loss or damage on any account whatsoever.

c) The Seller shall not in any event be liable for any loss or damage to the goods whilst in transit or where the goods are transported by an outside freight carrier.

8 Delivery

a) Any time or date for the dispatch or delivery of goods for the completion of work whether specified in the Seller's quotation or otherwise given by the Seller shall be taken as an estimate made by the Seller in good faith but shall not be binding upon the Seller either as a term of the contract or otherwise. In no circumstances shall the Seller be liable for any loss or damage sustained by the Customer in consequence of failure to deliver within such time or by such date or in consequence of any other delay in delivery however caused.

b) Unless otherwise agreed in writing delivery shall be made in the case of sales within the United Kingdom at the premises specified by the Customer and, in the case of export sales, at the United Kingdom port of shipment specified by the Customer. Subject to Condition e) below the risk in the goods shall pass to the Customer upon delivery or, in the case of export sales, upon the goods leaving the Seller's premises.

c) The Seller may deliver the goods in instalments and invoice the Customer as if each instalment comprised a separate contract upon the terms of these Conditions of Sale.

d) The Seller does not accept any responsibility for failure to deliver or a delay in delivery where such failure or delay is caused by other suppliers or contractors upon whom the Seller is reliant to ensure a timely delivery.

e) If delivery of the goods is delayed or prevented by any act or omission of the Customer, the Seller may put the goods into storage at the Customer's risk and expense. Any redeliveries will be at an extra cost as specified by the Seller, and the Customer will indemnify the Seller in relation to any losses, claims, expenses or liabilities which the Seller suffers or incurs as a result of such delay or prevention (including in particular but without limitation liabilities to any third party suppliers).

9 Acceptance

a) Acceptance of delivery of the equipment by the Customer or its agent shall be conclusive evidence that the equipment was delivered in good operating condition and in all respects in accordance with the contract under which it was supplied and that it was fit for any purpose for which it may be required by the Customer.

b) Shortage claims or claims that goods are defective or otherwise not in accordance with the contract, will only be considered if the Seller receives written notification thereof within seven days of delivery failing which no liability will be accepted.

10 Warranty

a) Subject to the conditions set out below the Seller warrants that the goods will correspond with their specification at the time of delivery and will be free from defects in material and workmanship:

b) The Seller shall be under no liability in respect of any defect in the goods arising from any drawing, design or specification supplied by the Customer.

c) The Seller shall be under no liability in respect of any defect arising from fair wear and tear, willful damage, negligence, abnormal working conditions, failure to follow the Seller's instructions (whether oral or in writing), misuse or alteration or repair of the goods without the Seller's approval,

d) Notwithstanding the terms of sub-clauses (a) and (b) above, the Seller's liability in respect of all goods supplied by it but manufactured by third parties shall be limited to such warranty as shall be provided by the manufacturer to the Seller and the Seller shall have no further or larger responsibility whatsoever.

e) Where goods are returned by the Customer to the Seller or the Seller's agent for warranty or other repair or calibration the Customer shall be responsible for all costs (including freight, duties and insurance) of delivering the goods to the Seller or the Seller's agent and/or at the Seller's option the manufacturer and the return of the goods thereafter to the Customer.

f) All goods returned must have full documentation as to the reason for the return. The Seller reserves the right to charge for time checking equipment which has no faults.

g) All other warranties or representations in respect of the goods expressed or implied by or under statute or custom or trade usage are hereby expressly excluded.

h) The Seller's entire liability in respect of any claim for loss or damage arising from the supply of goods or services (including the proper use of goods by the Customer) shall be limited to sum's recovered under the Seller's liability insurance. Without prejudice to the foregoing, the Seller shall not be liable for any consequential loss or damage (including, without limitation, loss of profits and goodwill).

11 Provision of Services

a) Where the Seller provides personnel to the Customer, the Customer shall not, without the prior written consent of the Seller use such personnel to undertake any work which, in the Seller's opinion, is inappropriate to their qualifications and experience, or which is not directly connected with the services If services are to be provided for an indeterminate period, then they will continue until terminated by either party giving to the other (thirty days') prior written notice.

b) The Customer shall be deemed to have been granted a licence to use any program or material supplied by the Seller in performing services for the period during which the services are performed only. This licence shall not entitle the Customer to grant any sub-licence or to provide these programs or materials for use or copying by any third party.

c) The Seller warrants that all services will be performed with reasonable skill and care. The Seller will not be liable for breach of this warranty unless the Customer reports the breach to the Seller within 1 month of completion of the services.

d) The Customer agrees that during a period of 6 months after completion or termination of any service provided by the Seller, it will not solicit the employment or services of any employee of the Seller who has been working in connection with the provision of services to the Customer

12 Lien

The Seller shall have a general lien in respect of all sums due from the Customer upon all goods to be supplied to such Customer or upon which work has been done on the Customer's behalf and, upon 14 days' written notice to the Customer, may sell such goods and apply the proceeds towards the satisfaction of the sums due to the Seller.

13 Force Majeure

The Seller shall not be liable for any delay or failure in the performance of any of its obligation hereunder if the delay or failure is due to causes outside its reasonable control and the Seller shall have the right at its option (a) to suspend further performance of the Contract until such time as the cause of the delay shall be no longer present; or (b) to be discharged from further performance of liability under the Contract and if the Seller exercises such right, the Customer shall thereupon pay the Contract Price less a reasonable allowance for what has not been performed by the Seller.

14 Descriptive Leaflets, Catalogues and Illustrations

All descriptive leaflets, catalogues, illustrations, specifications, drawings and other particulars issued by the Seller are approximate only and shall not form part of any contract between the Seller and the Customer unless specifically stated in writing by the Seller.

15 Representation by Seller's Employees

The Seller's employees or agents are not authorised to make any representations concerning the goods or services provided under the contract unless confirmed by the Seller in writing. In entering into the contract the Customer acknowledges that it does not rely on any such representations which are not so confirmed.

16 Copyright

Copyright in all drawings, specifications, designs, descriptions and documents issued by the Seller to the Customer or other third parties shall be and remain the property of the Seller and no copies shall be taken without the prior written consent of the Seller.

17 Licence Grant

The Seller hereby grants to the Customer a non-exclusive, non-transferable licence to use any programs supplied by the Seller for internal purposes only for the duration of the services provided by the Seller and on the equipment identified by the Seller. Any other use is prohibited. Such programs may not be used to provide a service to a third party without the prior written agreement of the Seller and subject to such extended use charges as the Seller may require.

18 Severance

a) While the restrictions and exclusions of the Customer's rights whether express or implied by common law, statute, custom of the trade, course of dealing or otherwise, are considered to be fair and reasonable having regard to the circumstances known to and in the contemplation of the parties at the date hereof, it is recognised that certain of the restrictions and exclusions may become unfair and unreasonable due to unforeseen circumstances and accordingly it is hereby agreed that if any of such restrictions and exclusions shall be adjudged to be void but would be valid if part of the wording thereof were deleted the said restriction or exclusion shall apply with such modifications as may be necessary to make it valid and effective.

b) If any condition herein shall be deemed void for any reason whatsoever, but would be valid if part of the wording thereof were deleted the said condition shall apply with such modifications as may be necessary to make it valid and effective.

19 General

a) Any notice required or permitted to be given by either party to the other under these Terms and Conditions of Sale shall be in writing addressed to that other party at its registered office or principal place of business or such other address as may at the relevant time have been notified pursuant to this provision to the party giving the notice.

b) No waiver by the Seller of any breach of the contract by the Customer shall be considered as a waiver of any subsequent breach of the same or any other provision.

c) If any of the provisions of these Terms and Conditions of Sale is held by any competent authority to be invalid or unenforceable in whole or in part the validity of the other provisions of these Terms and Conditions of Sale and the remainder of the provision in question shall not be affected.

d) These Terms and Conditions of Sale shall be governed and construed in all respects in accordance with the Laws of England. The Customer hereby submits to the non-exclusive jurisdiction of the English Courts in relation to these Terms and Conditions of Sale and all matters falling to be determined hereunder or in connection herewith.