

# **Installation and Operating Handbook**

## **P7001R & P7002R Converters**

Handbook Issue 1.03, 7<sup>th</sup> December 2015



PEAK COMMUNICATIONS Ltd.  
Unit 1, The Woodvale Centre, Woodvale Road,  
Brighouse, West Yorkshire  
HD6 4AB, England

Phone +44 (0)1484 714200  
Fax +44 (0)1484 723666

**IMPORTANT NOTE: THE INFORMATION AND SPECIFICATIONS  
CONTAINED IN THESE DOCUMENTS SUPERSEDE ALL PREVIOUSLY  
PUBLISHED INFORMATION CONCERNING THESE PRODUCTS**

# Table of Contents

<b>PRODUCT COMPLIANCE</b> .....	3
<b>Safety</b> .....	3
<b>EMC</b> .....	4
<b>1. INTRODUCTION</b> .....	4
1.1 General product overview .....	4
1.2 Functional description .....	6
1.3 Review of P700XR series generic specification parameters .....	6
1.3.1 UpConverter IF Input.....	6
1.3.2 UpConverter L / S / UHF-Band Output.....	6
1.3.3 DownConverter IF Output .....	6
1.3.4 DownConverter L / S / UHF-Band Input.....	7
1.3.5 Frequency Resolution .....	7
1.3.6 Phase noise (dBc/Hz).....	7
1.3.7 Group delay.....	7
1.3.8 UpConverter Conversion Gain .....	7
1.3.9 DownConverter Conversion Gain.....	7
1.3.10 Gain flatness .....	8
1.3.11 1dB Gain Compression Point.....	8
1.3.12 UpConverter Output spurious .....	8
1.3.13 Invert Spectrum.....	8
1.3.14 Auxiliary DC output.....	8
1.3.15 10MHz reference output.....	9
1.3.16 Internal Reference frequency.....	9
1.4 Mechanical description .....	9
1.7 Fault philosophy .....	14
<b>2. INSTALLATION</b> .....	16
2.1 Care of Your Product .....	16
2.1.1 Handling .....	16
2.1.2 Unpacking and Inspection.....	16
2.1.3 Storage.....	16
2.2 Mechanical Installation Considerations.....	16
2.2.1 Mounting.....	17
2.2.2 Cooling .....	17
2.3 Prime Power Supply & Connection .....	17
2.3.1 Fuses.....	17
2.3.2 Earthing.....	18
2.4 Other Interface Connections .....	18
2.4.1 L / S / UHF-Band Connections .....	18
2.4.2 L / S / UHF-band Monitor Output Connections (optional on some units) .....	18
2.4.3 IF Connections .....	18
2.4.4 External Reference Input Connections .....	19
<b>3. EQUIPMENT OPERATION</b> .....	19
<b>4. REDUNDANCY</b> .....	19
4.1 1 for 1 Redundancy (switched & passive).....	19
4.2 1 for 2 Redundancy.....	20
4.3 1 for N Redundancy .....	21
<b>5. REMOTE CONTROL</b> .....	22
5.1 Ethernet remote control (Optional).....	35

## CUSTOMER CARE

Contact the Peak Communications support department for:

- Product operation, application support or training requests
- Information for returning or upgrading a product
- Comments or suggestions on any supplied literature

### Contact Information

Peak Communications Ltd  
Attention: Support Department  
Unit 1, The Woodvale Centre  
Woodvale Road  
Brighouse  
HD6 4AB  
United Kingdom  
Tel. +44 (0) 1484 714200  
Fax +44 (0) 1484 723666  
E-mail [support@peakcom.co.uk](mailto:support@peakcom.co.uk)

You can also contact us via our website at [www.peakcom.co.uk](http://www.peakcom.co.uk)

To return a Peak Communications product for repair:

1. Contact the Peak Communications support department and request a Return Material Authorisation (RMA) number.
2. You will be required to provide to our support representative the model number, serial number and a detailed description of the problem.
3. To prevent any damage to the product during shipment we recommend that the unit is returned in its original packaging or if this is not available the packaging used must be of an equal standard.
4. Return the product back to Peak Communications and advise shipment details to support representative for tracking purposes. (Any shipping charges should be prepaid)

## PRODUCT COMPLIANCE

### Safety

To ensure safety of operator the P7000 series of converters have been designed to comply with the following safety standard;

EN 60950: Safety of information technology equipment, including electrical business machines.

Operation of the equipment in a non standard manner will invalidate compliance to this standard.

The equipment **MUST BE OPERATED WITH ITS LID ON AT ALL TIMES**. If it is necessary to remove the lid for any purpose then it is essential that the lid is fitted back correctly before normal operation.

**DANGEROUS VOLTAGES ARE PRESENT AROUND THE POWER SUPPLY AND PRECAUTIONS MUST BE TAKEN.**

## **EMC**

The P7000 Series of converters have been designed to comply with the following standards;

Emissions: EN 55022 Class B; Limits and methods of measurement of radio interference characteristics of Information Technology Equipment.

Immunity EN 50082 Part 1; Generic immunity standard, part 1: Domestic, commercial and light industrial environment.

Damage to the keyboard membrane or mechanical damage to the chassis will also invalidate compliance; please contact the factory under these circumstances for advice on continued operation.

Interfaces to the P7000 Series of converters must be made with suitably screened connectors and double screened coaxial cable. Data cables must be double screened.

All 'D' type connectors must have grounding fingers on the plug shell to guarantee continuous shielding. The back-shells must comply to the requirements of VDE 0871 and FCC 20708, providing at least 40 dB of attenuation from 30 MHz to 1 GHz.

Installations which do not comply with this requirement will invalidate the EMC specifications.

## **1. INTRODUCTION**

### **1.1 General product overview**

This manual covers the installation and operation of the P7001R and P7002R Up and Down frequency converters. A sample specification and review of generic specification parameters is incorporated in this manual, but is not guaranteed to be the latest specification or to represent all products covered by this manual, so please visit our website [www.peakcom.co.uk](http://www.peakcom.co.uk) for exact up to date specifications of the unit in question.

All P7000R series converters are housed in an IP66 diecast enclosure 290 x 230 x 95mm (11.4 x 9.1 x 3.7inch) and are designed to connect between a Modem IF, and provide an L or S-Band interface as required. The units are especially suitable for systems requiring an IBS and Eutelsat SMS compliant high stability low phase noise frequency converter for both data and analogue TV signals.

The units are under constant development and new features may not be included in this manual.

Models covered in this manual:-

<b>P7001R</b>	<b>L-Band to IF DownConverter</b>
<b>P7002R</b>	<b>IF to L-Band UpConverter</b>

The P7001R and P7002R units provide a high stability 10MHz reference signal and 22.5V DC power for both the transmit and receive paths to power an external Block Up and Downconverter. The P7000R series of converters will interface with the Peak CANBUS redundancy units for 1:1, 1:2 and 1:N systems (see RT1000R RT2000R and RCU1800 data sheets)

## 1.2 Functional description

The P700XR series will UpConvert a  $70 \pm 18\text{MHz}$  (optionally  $140\text{MHz} \pm 36\text{MHz}$ ) signal to a frequency within the L-Band range of 950-1750 MHz or S-Band range of 2.025-2.120GHz) and will DownConvert signals within the L-Band range of 950-2150MHz or S-Band range of 2.2-2.3GHz to  $70 \pm 18\text{MHz}$  (optionally  $140\text{MHz} \pm 36\text{MHz}$ ).

Both transmit and receive paths feature two stage frequency conversion and can be set to a frequency resolution of 1 Hz. The unit features a RS232/RS485 or optionally Ethernet remote control function for control and configuration of the unit. The units have built in 1:1 and 1:2 redundancy control.

The P700XR is fully software controlled; there are no links or switches used to configure the unit. This enables all control and configuration to be programmed remotely. All the configuration parameters are stored in non-volatile memory that will retain data for a minimum of 25 years with no power applied.

## 1.3 Review of P700XR series generic specification parameters

This section is provided to show typical values and explain the parameters involved. The specifications do vary between units and may change, so please refer to our website [www.peakcom.co.uk](http://www.peakcom.co.uk) for the latest up to date specifications.

### 1.3.1 UpConverter IF Input

$70 \pm 18 \text{ MHz}$  or option  $140 \pm 36\text{MHz}$

If the converter is set to output a frequency of 1200MHz then the centre frequency at 70 MHz (or 140MHz) will convert to this frequency. If you change the input frequency across the IF input band at 70MHz (using for example the modem frequency output control) without changing the output frequency then the output will be correspondingly lower/higher in frequency. If you input, for example 65MHz with the converter frequency set to 1200MHz the output will actually be 1195MHz. At all times the bandwidth of the signal should be calculated / measured so the  $\pm 18\text{MHz}$  at 70MHz (or  $\pm 38\text{MHz}$  at 140MHz) is not exceeded.

### 1.3.2 UpConverter L / S / UHF-Band Output

950-1750MHz (2025-2120MHz for S-Band, 390-450MHz for UHF-Band)

Centre frequency for a 70MHz (or 140MHz) input. A consideration of your signal bandwidth should be made because at 950MHz the lowest available frequency is  $950 - 18\text{MHz} = 932\text{MHz}$ , which means you could transmit out of band.

### 1.3.3 DownConverter IF Output

$70 \pm 18\text{MHz}$  or option  $140 \pm 36\text{MHz}$

As above for an UpConverter output, if the converter is set to input a frequency of 1200MHz then the centre frequency at 1200MHz will convert exactly to 70MHz (or 140MHz). If you input a frequency not exactly at the input frequency then the output will be similarly lower or higher by the same amount

### 1.3.4 DownConverter L / S / UHF-Band Input

950-2150MHz (2200-2300MHz for S-Band, 390-450MHz for UHF-Band) range of limit of input.

### 1.3.5 Frequency Resolution

1 Hz Output frequency step size.

### 1.3.6 Phase noise (dBc/Hz)

-65dBc/Hz @ 10Hz; -75dBc/Hz @ 100Hz; -80dBc/Hz @ 1kHz; -85dBc/Hz @ 10kHz; -95dBc/Hz @ 100kHz; -110dBc/Hz @ 1MHz. Typical depending on model

At 100Hz away from the carrier the average relative intensity of the carrier in CW mode at that point is 75dB lower than the centre frequency

### 1.3.7 Group delay

Linear 0.025nS, Parabolic 0.015nS/MHz<sup>2</sup>, Ripple 1nS p-p.

The relative timing distortion imposed on a signal passing through the converter within the  $\pm 18$ MHz band at 70MHz. This is due mainly to the internal filters. The group delay profile is described mathematically as follows

The linear function describes the straight line slope across the 36MHz range. At 0.025nS over 36MHz the slope across the pass band calculates to  $0.025 \times 36 = 0.9$ nS. The parabolic function is a quadratic function and can be converted at any point to a linear function by multiplying the specification parameter by the square of the frequency offset. For example for a Parabolic specification of 0.015nS/MHz<sup>2</sup> at a frequency of 60MHz the offset is 10MHz (70-60). This can be expressed in the form of an actual delay by calculating (70-60) squared x 0.015ns which is  $100 \times 0.015 = 1.5$ nS. This figure is always positive and the corresponding frequency at 80MHz calculates in this example to the same figure of 1.5nS. Note that the group delay is defined for a 70MHz IF and the group delay for a 140MHz is considerably improved especially the parabolic function.

The ripple parameter defines the limits of the balance of the group delay distortion after the linear and parabolic functions have been subtracted. This distortion is not necessarily a sinusoidal waveform and is important when considering high symbol rates

### 1.3.8 UpConverter Conversion Gain

Gain; +20dB  $\pm 1$ dB

Attenuation; 0-30dB, stepped 0.1dB

With maximum attenuation the Gain of the converter is set to -10dB (to lose 10dB through the conversion process) or with minimum attenuation to +20dB (to gain 20dB).

The finite gain set is specified to be within 2dB of the setting and the step size is 0.1dB.

The tolerance of the step size is not specified but should not exceed 0.05dB per step.

### 1.3.9 DownConverter Conversion Gain

Gain; +30dB  $\pm 1$ dB

Attenuation; 0-30dB, stepped 0.1dB

The gain of the converter can be set to have no gain (0dB) at maximum attenuation or a gain of 30dB at minimum attenuation. The finite gain set is specified to be within 2dB of the setting and the step size is 0.1dB.

#### 1.3.10 Gain flatness

±1.5dB full band, ±0.5dB, across any 36MHz in band

The slope and variation of power across the L/ S-Band should be within 2dB top to bottom, but within 1dB across any 36MHz.

#### 1.3.11 1dB Gain Compression Point

Output +10dBm, Input -10dBm

The 1dB compression point is a finite point in the power scale where a 1dB input only gives 0.5dB increase in power. At a gain of +20dB the output stage of the unit will compress before the input stage and conversely at gains of less than 20dB the input stage will compress before the output stage. Note also the values specified are for total composite power and not single carrier.

#### 1.3.12 UpConverter Output spurious

<-60dBm (in band non-carrier related), <-60dBc (in band carrier related)

All converters generate spurious signals due to Local Oscillator leakage inside the unit and possibly some mixing products of these oscillators. These signals are always present to some degree and are not related to the carrier signal being present so are specified as a maximum finite power in dBm and are always measured at full gain. Other signals associated with the carrier are also specified but relative to the carrier (dBc) and again measured at full gain. During manufacture only out of band signals in the minimum /2 and maximum x2 range are considered. Note that these spuri will be seen to change in finite value when gains other than full gain are selected due to switching of internal attenuators.

A typical setup is to set a converter input power of -20dBm and an output of 0dBm. Consideration of spuri should be made if the input power is significantly reduced as low input power will give a worse spurious to signal ratio.

#### 1.3.13 Invert Spectrum

In a conversion process if the Local oscillator used is of a higher frequency than the Input frequency then the output will be spectrum inverted. This means that the High Frequency side of an FM signal will come out at the Low Frequency side of the centre frequency. To decode a signal the decoder must know whether the signal is inverted and somewhere in the system there must be a mechanism to re-invert the signal. A classical example is the 5.15GHz oscillator used in a C-Band LNB. To convert the 3.4 to 4.2GHz band to 950MHz to 1750MHz a 2.45GHz LO is the calculated frequency. Unfortunately this 2.45GHz LO gives a problem due to twice the LO mixing with the input to give an interfering signal (4.9-3.4=1.5). A 5.15GHz LO is therefore used to avoid this problem and consequently the L-Band to 70MHz converter (P7001R) has to have INVERT enabled to preserve the spectrum. It is not normal to transmit inverted.

#### 1.3.14 Auxiliary DC output.



22.5 volts regulated @ 0.5 amp, software switchable.

This facility is used for driving an external L-Band to SHF BUC on an UpConverter and a BDC/LNB/LNA on a DownConverter. This voltage is integrated with the L-Band signal (along with the 10MHz, as appropriate). This voltage is generated by a regulator and will pull down to zero without damage, however the internal fuse may be damaged if this happens.

#### 1.3.15 10MHz reference output.

0dBm nominal, software switchable.

This facility is used for stabilising the output frequency of an external BUC/BDC. This signal is integrated with the L-Band signal. An outdoor BUC will drift in frequency due to ambient temperature changes causing changes to the BUC locking crystal inside the unit. Inside Peak BUC's and BDC's the facility is made to pick up the 10MHz locking signal sent by the P7000 series and lock to the internal crystal. With the BUC locked to the indoor unit, the stability of the BUC unit is as good as the internal P7000 crystal. With very long cables caution should be taken not to attenuate the 10MHz (and DC) too much.

#### 1.3.16 Internal Reference frequency.

A stable internally generated reference frequency of 10 MHz, trimmed by software.

Uses a high grade OCXO at 10MHz.

Accepts an External reference input of either 5 or 10MHz to lock the internal reference to a common 'station clock'.

Typical standard stability (higher stability options available);  $<5 \times 10^{-10}$  per second,  $<5 \times 10^{-9}$  per 12hrs, ageing  $<5 \times 10^{-7}$  per year and temperature stability of  $<5 \times 10^{-7}$  over 0 to +40deg.C.

### 1.4 Mechanical description

The P7001R/P7002R converters are housed in an outdoor mountable, waterproof environmentally sealed die cast enclosure as shown below.

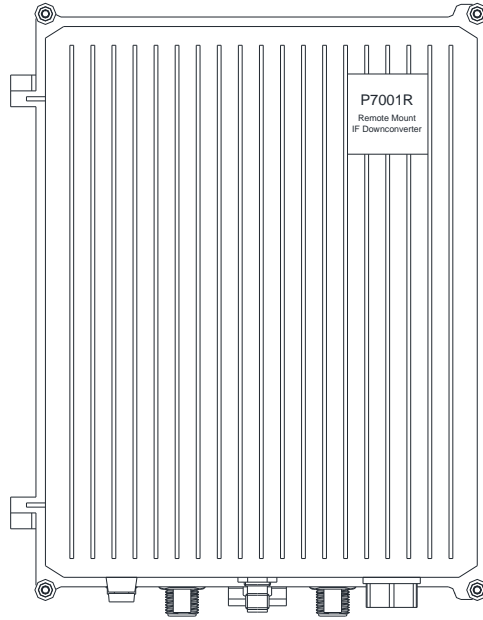

## Operation

Remote control is available from the front face connections in RS232/RS485 or with optional ethernet control. All internal oscillators are fed from a single internal reference, which can also be locked to an externally provided 10MHz reference frequency to ensure the system is stable and the changeover from one converter to another, minimizes traffic interruption. Customer supplied DC at 24V to 36V is internally fused to 1 amp and internally re-regulated to supply required voltages to the RF and supervisory circuitry. A form C summary alarm connection is available for monitoring the units unit via an M&C system.

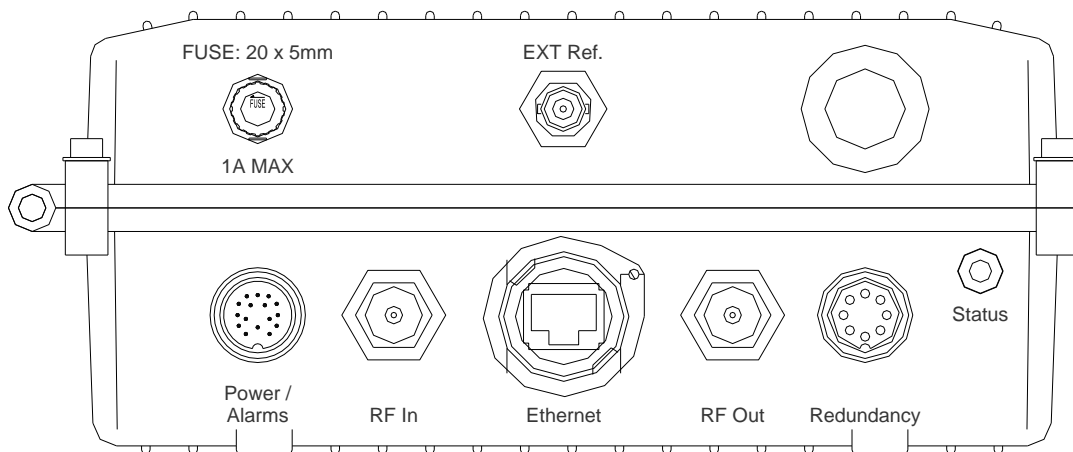

## P7001R/P7002R connector panel

The P7001R/P7002R converters have the following connections:

FUSE	Bulkhead mounting 20mm x 5mm 1Amp fuse removable by turning.
EXT REF	TNC Female connector for 10MHz reference supply.
BREATHER	Immersion proof breather.

POWER / ALARMS 16 Pin connector with connections as below. The cable used must be rated for 1Amp continuous use.

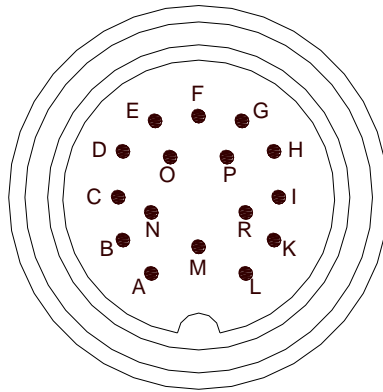

Pin number	Function	Description
A	Gnd	Chassis Gnd
B	RS232 Rx	RS232 Communication Rx
C	RS232 Tx	RS232 Communication Tx
D	RS485 Y	RS485 Communication Tx +
E	RS485 Z	RS485 Communication Tx -
F	RS485 B	RS485 Communication Rx -
G	RS485 A	RS485 Communication Rx +
H	External Alarm	Active low TTL pulled high internally
I	N/A	
K	N/A	
L	External Mute	Active low TTL pulled high internally
M	Alarm N/C	Form C dry contact summary alarm
N	Alarm Com	
O	Alarm N/O	
P	Gnd	Chassis Gnd
R	DC Supply	24V DC to 36V DC supply

External Mute & Alarm are selected when not shorted to Gnd, these inputs can be set to be ignored via the Web Interface if required.

RF IN                      N-Type Female connector, input at L-band range is 950 to 2150MHz.

ETHERNET                Sealed RJ45 connector fitted, cover must remain in place to keep IP rating when not in use

RF OUT                    N-Type Female connector, output in the range 70 MHz ± 18MHz

**REDUNDANCY INTERFACE** 8 pin connector with connection as below. The cable used must be rated for 1Amp continuous use.

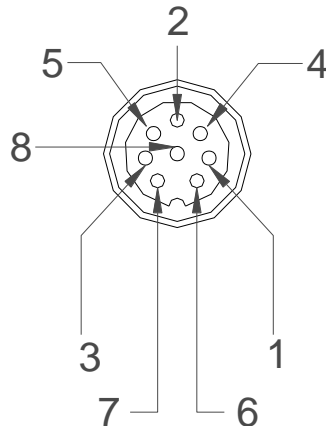

Pin number	Function
1	Can Bus Low
2	Gnd
3	Power A
4	Power B
5	Gnd
6	Can Bus High
7	Tellback A
8	Tellback B

**STATUS** Online indication, Green = online, Amber = offline, Red = alarm

## 1.7 Fault philosophy

Fault conditions are divided into two categories;

- a) MAIN UNIT COMMON FAULTS; Faults with internal items that effect the overall unit (Main power supply assembly etc).
- b) DEVICE SPECIFIC FAULTS; Faults that are specific to the Up or DownConverter assemblies. These can include external fault inputs.

Most faults as shown below activate the summary ALARM on the unit, this will force a change-over if used in a normal redundant system.

The only fault that does not cause the unit to go into ALARM is the 'External Mute'. All faults shown below are reported the remote interface and turn the tri-colour fault LED to red.

Green – No faults

Amber – Unit in standby

Red – Fault condition

The MUTED column shows if the output is muted when the ALARM is active.

*MAIN UNIT COMMON FAULTS:*

<b>Fault Name</b>	<b>MUTED</b>	<b>SUMMARY ALARM</b>
Primary DC Power Supply	No	Yes
Over/Under Temperature	No	Yes
External Reference Fault	Yes	Yes
Crystal Fault	Yes	Yes
Redundancy Coax Switch	Yes	Yes

*DEVICE SPECIFIC FAULTS;*

*UPCONVERTER:*

<b>Fault Name</b>	<b>MUTED</b>	<b>SUMMARY ALARM</b>
+3 VDC Power Supply	No	Yes
+5 VDC Power Supply	No	Yes
+15 VDC Power Supply	No	Yes
Primary DC Power Supply	No	Yes
1 <sup>st</sup> LO Fault	Yes	Yes
2 <sup>nd</sup> LO Fault	Yes	Yes
815MHz Fault	Yes	Yes
External Fault	No	Yes
External Mute	Yes	No
Internal Communications	No	Yes

*DOWNCONVERTER:*

<b>Fault Name</b>	<b>MUTED</b>	<b>SUMMARY ALARM</b>
+3 VDC Power Supply	No	Yes
+5 VDC Power Supply	No	Yes
+15 VDC Power Supply	No	Yes
Primary DC Power Supply	No	Yes
1 <sup>st</sup> LO Fault	Yes	Yes
2 <sup>nd</sup> LO Fault	Yes	Yes
External Fault	No	Yes
External Mute	Yes	No
Internal Communications	No	Yes

## 2. INSTALLATION

### 2.1 Care of Your Product

#### 2.1.1 Handling

The shipping carton is qualified for transit of these products and has been used successfully for many years. It will protect against shock and vibration encountered during normal carrier transportation.

PLEASE RETAIN ALL PACKING MATERIALS, including the foam insets. Should the unit need to be returned, return to the address on the front of the manual USING THE ORIGINAL PACKING CARTON, unless it has been seriously damaged.

Avoid subjecting the packaged or unpackaged product to severe shocks.

#### 2.1.2 Unpacking and Inspection

When the product is first received, the outer pack should be inspected for signs of damage. If damage to the outer pack is evident, contact the Carrier immediately and submit a damage report. The equipment should then be removed and inspected for signs of damage, retaining all packing materials. Any visible signs of damage to the equipment should be reported immediately to Peak Communications (electronic photo's of the pack and equipment can help with any subsequent insurance claims). If the equipment appears undamaged, it should be tested for correct operation and again any abnormalities reported to Peak Communications.

When first removing the product from its transit pack, take care to retain all documentation and associated hardware. These products are typically provided with the following items;

- P700XR series product.
- Operation Manual.
- Test Results.
- Spares Kit.

If you suspect that any item is missing, please contact Peak Communications immediately.

#### 2.1.3 Storage

Store the product in the normal horizontal orientation, in its outer carton until it is required for use. Do not use the products to support the weight of other items whilst in storage.

Storage temperature range is typically from -40°C to +80°C, avoid exceeding these extremes otherwise damage may result.

Avoid exposing the packaged or unpackaged product to extremes of humidity or moisture (including condensation). In the event that this does occur, the product should be left at room temperature for in excess of 5 hours to dry naturally before application of prime power.

### 2.2 Mechanical Installation Considerations



### 2.2.1 Mounting

The product can be mounted using the multiple mounting holes supplied on the bracket. Alternatively the mounting brackets may be removed and the unit mounted using the 4 hole on the base of the unit, however the correct length of screw must be used to prevent damage to the unit

### 2.2.2 Cooling

Unit must be mounted in a position to minimise solar gain and provide cooling via the mounting bracket.

## 2.3 Prime Power Supply & Connection

24VDC to 36VDC required to power these units.

### 2.3.1 Fuses

The equipment is provided with short circuit fuse protection. The fuse size is 5 x 20 mm, rated at 1A and is replaceable via the fuse holder on the front face of the units.

### 2.3.2 Earthing

An external protective earth, providing protection against RF and transient currents, should be connected to the mounting bracket.

## 2.4 Other Interface Connections

### 2.4.1 L / S / UHF-Band Connections

These are provided on the front face and have the following characteristics;

Converter Type	Connection Type	Panel Label	Impedance
UpConverter	N-type (female)	'RF Out'	50Ω
DownConverter	N-type (female)	'RF In'	50Ω

The use of high quality cables and connectors for L / S / UHF-band signals is strongly recommended. Cables and connectors should be rated for operation up to 2200MHz for L-Band and 2500MHz (or above, as appropriate) for S-Band. Care should be taken when handling these cables, avoiding stress to connections, tight bend radii and damage from sharp objects, all of which can degrade system performance. Depending upon the unit type, these connections can also be used to interface the 10MHz reference signal (at a nominal 0dBm level) and the DC power (+22.5V @ 0.5A) to the external BUC/BDC/LNA/LNB, as appropriate.

### 2.4.2 L / S / UHF-band Monitor Output Connections (optional on some units)

These are provided on the front face and have the following characteristics;

Converter Type	Connection Type	Panel Label	Impedance	Notes.
UpConverter	TNC (f)	'L-Band' or 'L-Band Monitor'	50Ω	Monitors L/ S / UHF-band output to BUC or HPA.
DownConverter	TNC (f)	'L-Band' or 'L-Band Monitor'	50Ω	Monitors L/ S-band input from BDC, LNB or LNA.

Monitor signal levels are typically -20dBc ±3dB.

### 2.4.3 IF Connections

These are provided on the front face and have the following characteristics;

Converter Type	Connection Type	Panel Label	Impedance	Notes.
UpConverter	N-type (female)	'RF In'	50Ω	Optional 75Ω impedance.
DownConverter	N-type (female)	'Rf Out'	50Ω	Optional 75Ω impedance.

The IF input frequency should be within the range 50 to 90 MHz (100 to 180MHz with the 140MHz option).

## 2.4.4 External Reference Input Connections

These are provided on the front face and have the following characteristics;

Converter Type	Connection Type	Panel Label	Impedance	Notes.
All	TNC (f)	'EXT Ref.'	50Ω	Accepts 5 or 10MHz (factory selectable).

## 3. EQUIPMENT OPERATION

The P7001R and P7002R models are L-Band based and have additional features for integration with SHF Block converters (BUC and BDC units).

A typical simple UpConverter system incorporating a P7002 could consist of a P7002R connected directly to a remote outdoor BUC. The P7002R powers and controls the BUC by supplying DC Power, a Locking frequency for the BUC internal oscillator and the correct L-Band input power and frequency. The P7002R monitors the alarm status of the BUC to give the operator indication of the condition of the outdoor BUC unit.

A similar typical simple DownConverter system could also consist of a P7001 being connected to an LNB on the antenna and providing DC Power, a locking frequency for the LNB oscillator and receiving the L-Band signal.

In these situations the DC and 10MHz signals can be switched on and off and the frequency on the P7000R series unit can be set to include the frequency of the remote Block converter.

## 4. REDUNDANCY

The P7000R series of frequency converters interface with the Peak CANBUS redundancy system for 1+1, 2+1 and n+1 redundancy systems.

### 4.1 1 for 1 Redundancy (switched & passive)

For 1+1 switched redundant operation a pair of P7000R series units are required along with an R1000 for receive applications and T1000 for Transmit applications.

In use, the redundancy type on the configuration/ redundancy menu is set to 1+1, one unit is set to identifier "A" and the other to identifier "B". The T1000R or R1000R units are connected to the converter panel 9-way 'redundancy' connectors with the supplied cables, the units will self detect and automatically set one unit to online and the other to standby.

If the units are in Automatic redundancy mode then an alarm detected in the online unit will result in the configuration of the online unit being adopted by the standby and then the standby will be switched to the RF path, becoming the online unit.

If the units are in Manual redundancy mode then the units will stay in their online/offline positions no matter what the state of the other unit.

In redundancy either mode the standby unit can be made to go online by the changeover option in the menu.

#### 4.2 1 for 2 Redundancy

For 2+1 switched redundant operation a Trio of P7xxxR series units are required along with an R2000R for receive applications, a T2000R for Transmit applications.

In use, the redundancy type on the configuration / redundancy menu is set to 2+1, one unit is set to identifier "A", the second to identifier "B" and the third to "Standby". The R2000 or T2000 units are connected to the converter rear panel 9-way 'redundancy' connectors with the supplied cables and the units self detect. A changeover will be caused by an alarm detected in an online unit or changeover (keypad '4') being selected, this will result in the configuration of the online unit being adopted by the standby unit and then the standby will be switched to the RF path, becoming an online unit. Priority can be set on paths A and B, so that if there is a second failure the higher priority path will remain operational, if both units are set to priority 1 then this function will be ignored.

### 4.3 1 for N Redundancy

For 3+1 to 8+1 switched redundant operation the RCU1000 series of redundancy units are available (see appropriate data sheet for specification).

## 5. REMOTE CONTROL

The unit transmits and receives data serially in an asynchronous format using the standard ASCII character set. The serial data consists of message frames composed of the following message characters: STX, BYTE COUNT, DEVICE ADDRESS, INSTRUCTION, BODY, CHECKSUM, ETX. All characters are compulsory except for the message body. The presence of a message body is determined by the message type (INSTRUCTION). The total number of message characters in a message frame may range from a minimum of 6 to a maximum of 255.

The remote control follows the following protocol: (in byte form)

[STX] start of message character #02.

[B] char defining how many characters are in the message including the STX & ETX parts.

[A] **Address of unit.** Address ranges from ASCII character 001 to 255.

[I] **Instruction number.**  
See List below

[MESSAGE]

Numerous characters from length 0 upwards.

[CHKSUM]

The checksum is used to verify the accuracy of the message frame. The checksum is defined as the summation of all the bytes in the message, **beginning** with the 3rd byte (DEVICE ADDRESS) and extending through the body of the message, **ending** with the last byte before the checksum. The total of the bytes is then ANDed with 255 so that the checksum is truncated to a single byte.

[ETX] End of transmission character #03

All message to and from the unit follow the above protocol with a character format of 8 data bits, one stop bit, no parity, baud rate 19200, 9600, 4800, 2400, 1200 or 300. Note that all numeric values are shown as decimal.

**Instruction Number List: (in decimal) (P7001R, P7002R):**

To P7XXXR unit	From P7XXXR unit	Description
4		Requests Ethernet settings status
	5	Responds with Ethernet settings status
6		
20		Requests Rx/Tx Status
	21	Responds with Rx/Tx Status
22		Requests Rx/Tx setting changes
24		Set Remote/Local Mode request
26		Serial Communications Configuration
40		Asks for the main Unit settings
	41	Replies with the Unit Settings
45		Requests redundancy status
	46	Responds with redundancy status
47		Requests redundancy changes

## Ethernet Settings Status Message

This message is sent to the unit, when the host computer wishes to query the Ethernet settings. These Ethernet messages have an Instruction number as well as a subinstruction.

### **Instruction 4, Subinstruction 1 (Ethernet Status Request):**

Message Byte No.	Set Value / (example)	Length (bytes)	Description
1	02	1	STX
2	7	1	No of bytes in message
3	?	1	Address
4	4	1	Message instruction
5	'1'	1	Ethernet Message sub instruction
6	?	1	Checksum
7	03	1	ETX

The unit then responds with the following message:

### **Instruction 5, Subinstruction 1 (Ethernet Status Reply):**

Message Byte No.	Set Value / (example)	Length (bytes)	Description
1	02	1	STX
2	7	1	No of bytes in message
3	?	1	Address
4	5	1	Message instruction
5	'1'	1	Ethernet Message sub instruction
6	'0'	1	DHCP (0 = Disabled) (1 = Enabled)
7	' '	1	Separator character
8	"192.168.000.025"	15	Ipv4 address
23	' '	1	Separator character
24	"255.255.255.0"	15	Subnet mask
39	' '	1	Separator character
40	"192.168.000.010"	15	Gateway address
55	' '	1	Separator character
56	'0'	1	SNMP (0 = Disabled) (1 = Enabled)
57	' '	1	Separator character
58	"192.168.000.032"	15	SNMP trap address
73	?	1	Checksum
74	03	1	ETX



## Ethernet Configure Message

This message is sent to the unit, when the host computer wishes to change the Ethernet settings of the unit, subject to the fitting on the Ethernet option. The unit does not need to be in remote mode for this to be achieved.

The layout of the configure message follows that of the status reply shown above.

### **Instruction 6, Subinstruction 1 (Ethernet Reconfiguration Request):**

Message Byte No.	Set Value / (example)	Length (bytes)	Description
1	02	1	STX
2	7	1	No of bytes in message
3	?	1	Address
4	6	1	Message instruction
5	'1'	1	Ethernet Message sub instruction
6	'0'	1	DHCP (0 = Disabled) (1 = Enabled)
7	' '	1	Separator character
8	"192.168.000.025"	15	Ipv4 address
23	' '	1	Separator character
24	"255.255.255.0"	15	Subnet mask
39	' '	1	Separator character
40	"192.168.000.010"	15	Gateway address
55	' '	1	Separator character
56	'0'	1	SNMP (0 = Disabled) (1 = Enabled)
57	' '	1	Separator character
58	"192.168.000.032"	15	SNMP trap address
73	?	1	Checksum
74	03	1	ETX

When changing IP address or DHCP the unit will have to restart, it may take a few seconds for you to be able to communicate with it again.

### TCP Port Status Message

This message is sent to the unit, when the host computer wishes to query the TCP port number, subject to the fitting of the Ethernet option.

#### Instruction 4 Subinstruction 2 (TCP Port Status Request):

Message Byte No.	Set Value / (example)	Length (bytes)	Description
1	02	1	STX
2	7	1	No of bytes in message
3	?	1	Address
4	4	1	Message instruction
5	'2'	1	TCP port sub instruction
6	?	1	Checksum
7	03	1	ETX

The unit then responds with the following message:

#### Instruction 5 Subinstruction 2 (TCP Port Status Reply):

Message Byte No.	Set Value / (example)	Length (bytes)	Description
1	02	1	STX
2	7	1	No of bytes in message
3	?	1	Address
4	5	1	Message instruction
5	'2'	1	TCP port sub instruction
6	"04000"	5	TCP Port number
11	' '	1	Separator character
12	"00010"	5	TCP Socket timeout in seconds
17	?	1	Checksum
18	03	1	ETX

### TCP Port Status Message

This message is sent to the unit, when the host computer wishes to change the TCP port setting of the unit, subject to the fitting on the Ethernet option. The unit does not need to be in remote mode for this to be achieved.

The layout of the configure message follows that of the status reply shown above.

#### Instruction 6 Subinstruction 2 (TCP Port Reconfiguration Request):

Message Byte No.	Set Value / (example)	Length (bytes)	Description
1	02	1	STX
2	7	1	No of bytes in message
3	?	1	Address
4	6	1	Message instruction
5	'2'	1	TCP port sub instruction
6	"04000"	5	TCP Port number
11	' '	1	Separator character
12	"00010"	5	TCP Socket timeout in seconds
17	?	1	Checksum
18	03	1	ETX

**Instruction 20 (Rx/Tx Status Request):**

Message Byte No.	Set Value / (example)	Length (bytes)	Description
1	02	1	STX
2	?	1	No of bytes in message
3	?	1	Address
4	20	1	Message instruction
5	('R')	1	Device we are asking the information for: 'R' = Receive 'T' = Transmit
6	?	1	Checksum
7	03	1	ETX

**Instruction 21 (Rx/Tx Status Request Reply) (P7001R, P7002R):**

Message Byte No.	Set Value / (example)	Length (bytes)	Rx	Tx	Description
1	02	1	✓	✓	STX
2	?	1	✓	✓	No of bytes in message
3	?	1	✓	✓	Address
4	21	1	✓	✓	Message instruction
5	('R')	1	✓	✓	Device we are asking the information on: 'R' = Receive 'T' = Transmit
6	('10123456789' = 10.123456789 Ghz)	11	✓	✓	Frequency in Hz The Lband Frequency of the unit.
17	(' +0123' = 12.3 dB)	5	✓	✓	Gain in 0.1dB steps Lband gain of the converter NOT the overall SHF gain
22	('1')	1	✓	✗	Spectrum Invert ON/OFF '0' = OFF '1' = ON
23	('1')	1	✗	✓	Carrier ON/OFF '0' = OFF '1' = ON
24	('1')	1	✓	✓	10MHz ON/OFF '0' = OFF '1' = ON
25	('1')	1	✓	✓	DC Feed ON/OFF '0' = OFF '1' = ON
26	('1')	1	✓	✓	IF Frequency '0' = 70Mhz '1' = 140MHz
27	('1')	1	✓	✓	SHF LO ON/OFF '0' = OFF '1' = ON
28	?	11	✓	✓	SHF Frequency in Hz
39	?	1	✓	✓	SHF Spectrum Invert
40	('1')	1	✗	✓	SHF Gain ON/OFF '0' = OFF '1' = ON
41	('+999' = +99.9 dB)	4	✗	✓	SHF Gain in 0.1dB steps
45	('+999' = +99.9 dB)	4	✗	✓	SHF Gain I/P power in 0.1dB steps
50	('0')	1	✓	✓	3V voltage out of range fault '0' = OK '1' = FAULT
51	('0')	1	✓	✓	5V voltage out of range fault '0' = OK '1' = FAULT
52	('0')	1	✓	✓	15V voltage out of range fault '0' = OK '1' = FAULT
53	('0')	1	✓	✓	Primary voltage out of range fault '0' = OK '1' = FAULT
54	('0')	1	✓	✓	Fault 1: Rx : 1ST LO Fault Tx: 1ST LO Fault '0' = OK '1' = FAULT
55	('0')	1	✓	✓	Fault 2: Rx: '0' Fault not used Tx: 815MHz LO Fault '0' = OK '1' = FAULT
56	('0')	1	✓	✓	Fault 3: Rx : 1ST LO Fault

					Tx: 1ST LO Fault '0' = OK '1' = FAULT
57	('0')	1	✓	✓	External Alarm Fault '0' = OK '1' = FAULT
58	('0')	1	✓	✓	External Mute '0' = OK '1' = MUTED
59	('0')	1	✓	✓	Internal Communications Fault '0' = OK '1' = FAULT
60	('23/12/02 12:34:56')	17	✓	✓	OK Since time/date string. If the SNTP time is not valid then the string is "OK" If there is a fault with this up/down converter section then the string is "NOT OK".
77	?	1	✓	✓	Checksum
78	03	1	✓	✓	ETX

**Instruction 22 (Rx/Tx Reconfiguration Request):**

The message body for this message is a truncated form of the Rx/Tx Status Request Reply (instruction 21)

i.e. no information after the SHF Gain I/P power parameter is sent.

Not all parameters have to be set, if the user doesn't wish to change a particular parameter then a number of 'x's can be sent in the parameter's place. Sending such data will ensure that the unit ignores that particular parameter.

'x's should also be sent in place of parameters that are not used by the particular unit type.

The unit **MUST** be in remote mode to allow reconfiguration of parameters via the remote control. Setting the unit in Remote mode can be done either by the front panel or remotely using the following command:

**Instruction 24 (Set Remote/Local Mode):**

Message Byte No.	Set Value / (example)	Length (bytes)	Description
1	02	1	STX
2	?	1	No of bytes in message
3	?	1	Address
4	20	1	Message instruction
5	('R')	1	'R' = Remote Mode 'L' = Local Mode
6	?	1	Checksum
7	03	1	ETX

**Serial Communications Configuration Message**

Due to the lack of a front panel on these converters it is possible to change their address, baudrate and whether they use RS232 or RS485 communications via a serial message. The P7001R/P7002R will change its serial configuration only if all the settings are valid in the message.

**Instruction 26 (Serial Communications Configuration):**

Message Byte No.	Set Value / (example)	Length (bytes)	Description
1	02	1	STX
2	14	1	No of bytes in message
3	?	1	Address
4	26	1	Message instruction
5	'2'	1	RS232/RS485 selection '2' – RS232 '4' – RS485
6	' '	1	Address: Valid range is character 1 to 255 (incl.)
7	'1'	1	Baudrate: '1' – 300 '2' – 1200 '3' – 2400 '4' – 4800 '5' – 9600 '6' – 19200
8	?	1	Checksum
9	03	1	ETX

The unit MUST be in remote mode to allow reconfiguration of parameters via the remote control.

**Instruction 40 (Unit Status Request):**

Message Byte No.	Set Value / (example)	Length (bytes)	Description
1	02	1	STX
2	?	1	No of bytes in message
3	?	1	Address
4	40	1	Message instruction
5	?	1	Checksum
6	03	1	ETX

**Instruction 41 (Unit Status Request Reply):**

Message Byte No.	Set Value / (example)	Length (bytes)	Description
1	02	1	STX
2	?	1	No of bytes in message
3	?	1	Address
4	41	1	Message instruction
5	(' P7001R')	27	Type of unit this is: P7001R, P7002R
32	('01234' = Serial No 01234)	5	Serial Number
37	('0112.34')	7	Software Version Number
44	('0' = OK)	1	Summary Alarm OK/FAULT '0' = OK '1' = FAULT
45	('0')	1	Primary DC voltage out of range fault '0' = OK '1' = FAULT
46	('0')	1	Temperature out of range fault '0' = OK '1' = FAULT
47	('0')	1	External Reference fault '0' = OK '1' = FAULT
48	('0')	1	Crystal fault '0' = OK '1' = FAULT
49	('0')	1	Coax Switch fault '0' = OK '1' = FAULT
50	('23/12/02 12:34:56')	17	OK Since time/date string. If the SNTP time is not valid then the string is "OK" If there is a fault with this units section then the string is "NOT OK".
67	('0')	1	1:1 Status '0' = Offline '1' = Online
68	('0')	1	Remote mode '0' = Local '1' = Remote
69	('0')	1	External Reference '0' = Off '1' = On
70	?	1	Checksum
71	03	1	ETX

**Instruction 45 (Redundancy Status Request):**

Message Byte No.	Set Value / (example)	Length (bytes)	Description
1	02	1	STX
2	?	1	No of bytes in message
3	?	1	Address
4	45	1	Message instruction
5	?	1	Checksum
7	03	1	ETX



**Instruction 46 (Redundancy Status Request Reply):**

Message Byte No.	Set Value / (example)	Length (bytes)	Description
1	02	1	STX
2	?	1	No of bytes in message
3	?	1	Address
4	46	1	Message instruction
5	('1')	1	Redundancy Type Configuration '1' = 1 for 1 '2' = 1 for 2 'N' = 1 for N
6	('M')	1	Redundancy Manual Mode 'M' = Manual 'A' = Auto 'X' = Units setup as 1 for 1 type
7	('0')	1	Online Status '0' = Offline '1' = Online
8	('A')	1	Unit Identifier 'A' or 'B' when in 1 or 1 configuration 'A' or 'B' or 'S' when in 1 or 2 configuration
9	('1')	1	Unit Priority 'X' when in 1 for 1 configuration or if units are selected as standby '1' or '2' when in 1 for 2 configuration
10	('A')	1	Unit Online 'A' or 'B' when in 1 for 1 configuration. 'A' or 'B' or 'S' when in 1 for 2 configuration and the unit selected as standby otherwise 'X' '@' means no redundant controller attached, unit online not known.
11	('1')	1	Coax Switch Position '1' or '2' '@' means no redundant controller attached , position not known
12	?	1	Checksum
13	03	1	ETX

### **Instruction 47 (Redundancy Change Request):**

When a unit is in a 1 for 1 configuration only the “Unit To Go Online” parameter in the message below can be manipulated on the currently OFFLINE unit.

When a unit is in a 1 for 2 configuration if the unit is selected as standby then all the parameters can be modified apart from the unit priority. However, if the unit is selected as either A or B, then only the priority can be changed for that particular unit.

Message Byte No.	Set Value / (example)	Length (bytes)	Description
1	02	1	STX
2	?	1	No of bytes in message
3	?	1	Address
4	47	1	Message instruction
5	('1')	1	Redundancy Type Configuration '1' = 1 for 1 '2' = 1 for 2 'N' = 1 for N
6	('M')	1	Redundancy Manual Mode 'M' = Manual 'A' = Auto
7	('A')	1	Unit Identifier 'A' or 'B' when in 1 or 1 configuration 'A' or 'B' or 'S' when in 1 or 2 configuration
8	('S')	1	Unit To Go Online 'A' or 'B' when in 1 for 1 configuration. 'A' or 'B' or 'S' when in 1 for 2 configuration and the unit selected as standby
9	('1')	1	Unit Priority '1' or '2' when in 1 for 2 configuration '1' .. '8' when in 1 for n configuration
10	?	1	Checksum
11	03	1	ETX

## 5.1 Ethernet remote control (Optional)

The Ethernet option for the P7xxxR series products adds the ability to control the unit by Ethernet as well as by the existing standard RS232 or RS485, this is achieved via a separate module within the unit.

The unit can be controlled through the Ethernet port using three different approaches.

### TCP Port

The unit can be controlled using the serial remote control messages as described earlier sent through the TCP port set in the Ethernet menu option. The address is fixed at 32.

### Web Page

The unit can be controlled via the in-built web server's web page. There are two pages, Status and Configure. Hopefully both of which are self explanatory.

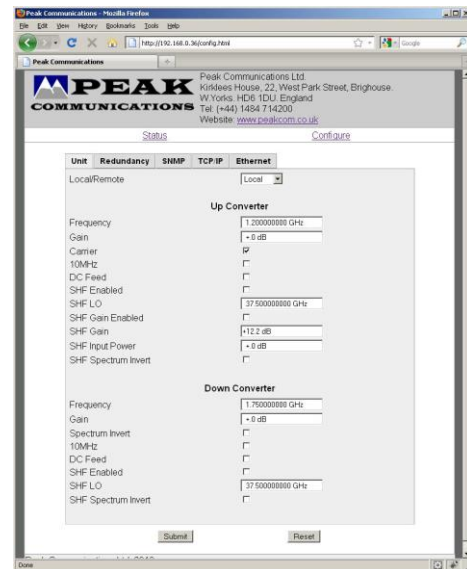
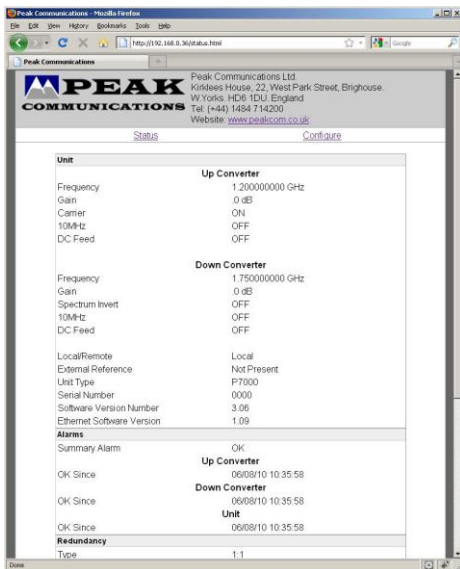

### SNMP

The P7xxx series units fitted with Ethernet, have built-in SNMP (Simple Network Management Protocol) agent software.

It supports SNMP Trap, RFC1155, 1157, 1212, 1213, 1901 & 1906, as well as the Peak MIBS.

The Peak SNMPv2 MIB files are supplied by Peak Communications Ltd, below is a quick overview of them.

The Peak Enterprises node is essentially split into three main areas:

*Converters* - In this node there are numerous nodes:

    peakUpConverterModule showing a table of the Up Converter module.

    peakDownConverterModule showing a table of the Down Converter module.

These tables show the current settings of the converter module and allow their reconfiguration.

*Unit* – This node allows the unit status to be checked as well as the Ethernet and redundancy settings.

*PeakFaultsModule* – This node contains the unit summary alarm as well as a table showing all the faults currently on the unit.

